

STANDARD SYSTEM DIAGRAM

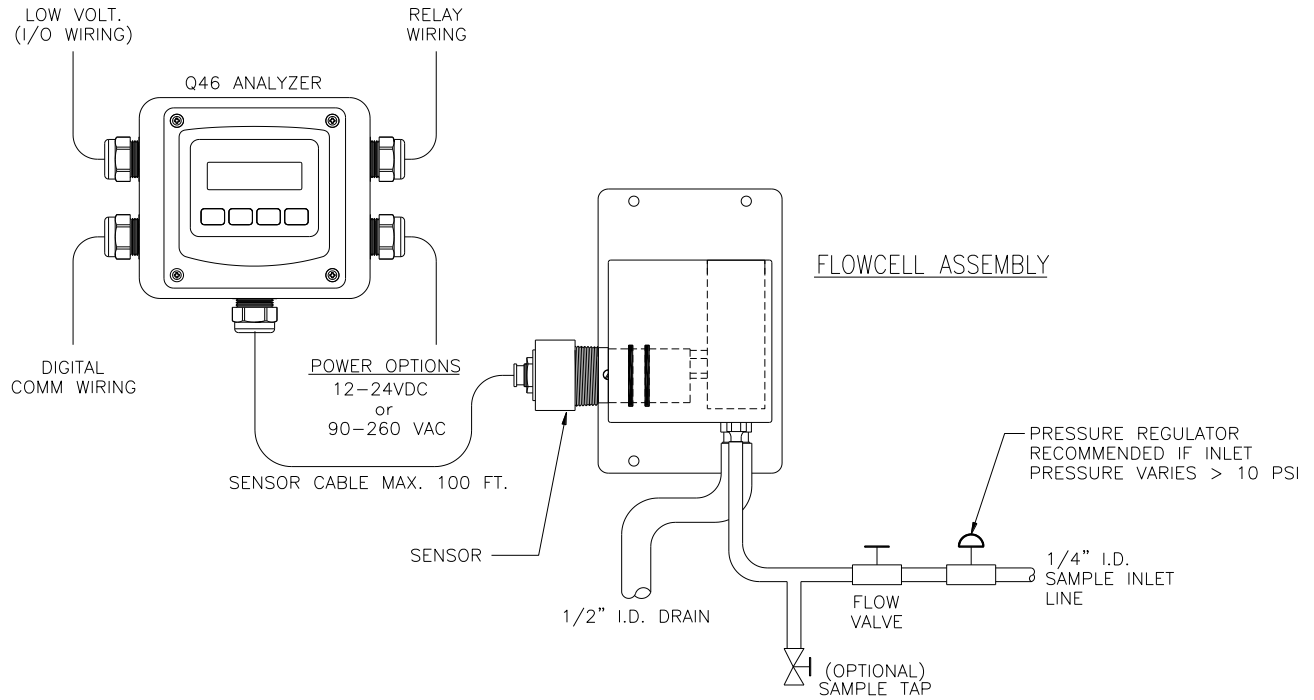

ATI-0922

SYSTEM DIAGRAM w/SEALED FLOWCELL

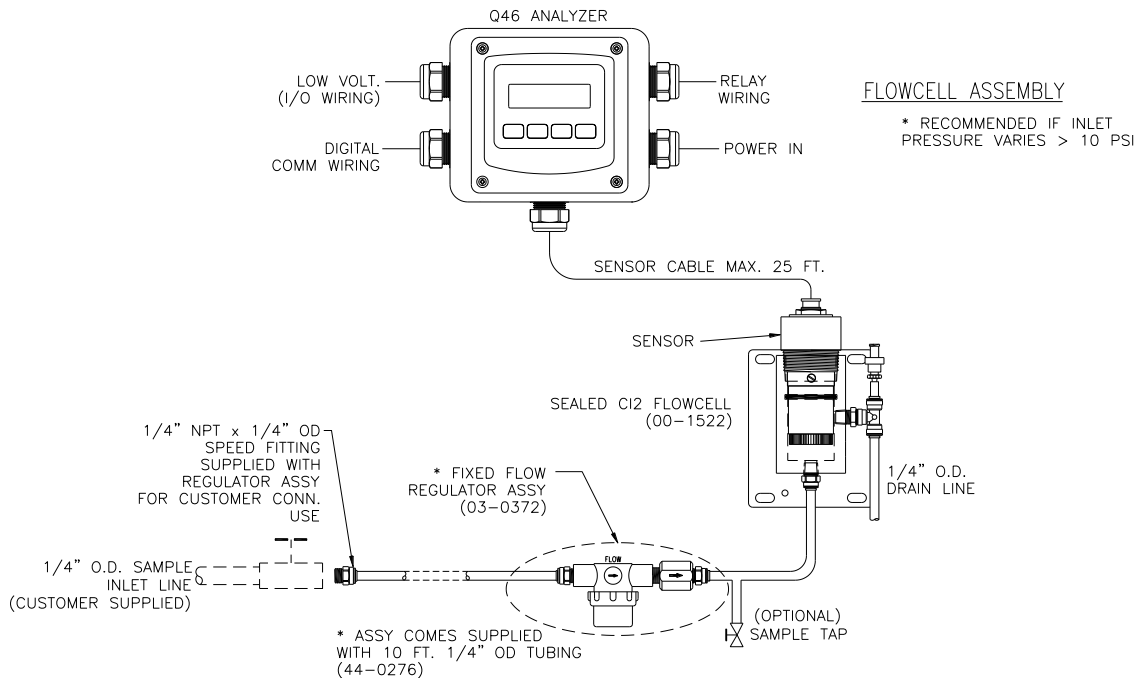

ATI-0924

SYSTEM MOUNTING PLATE ASSY

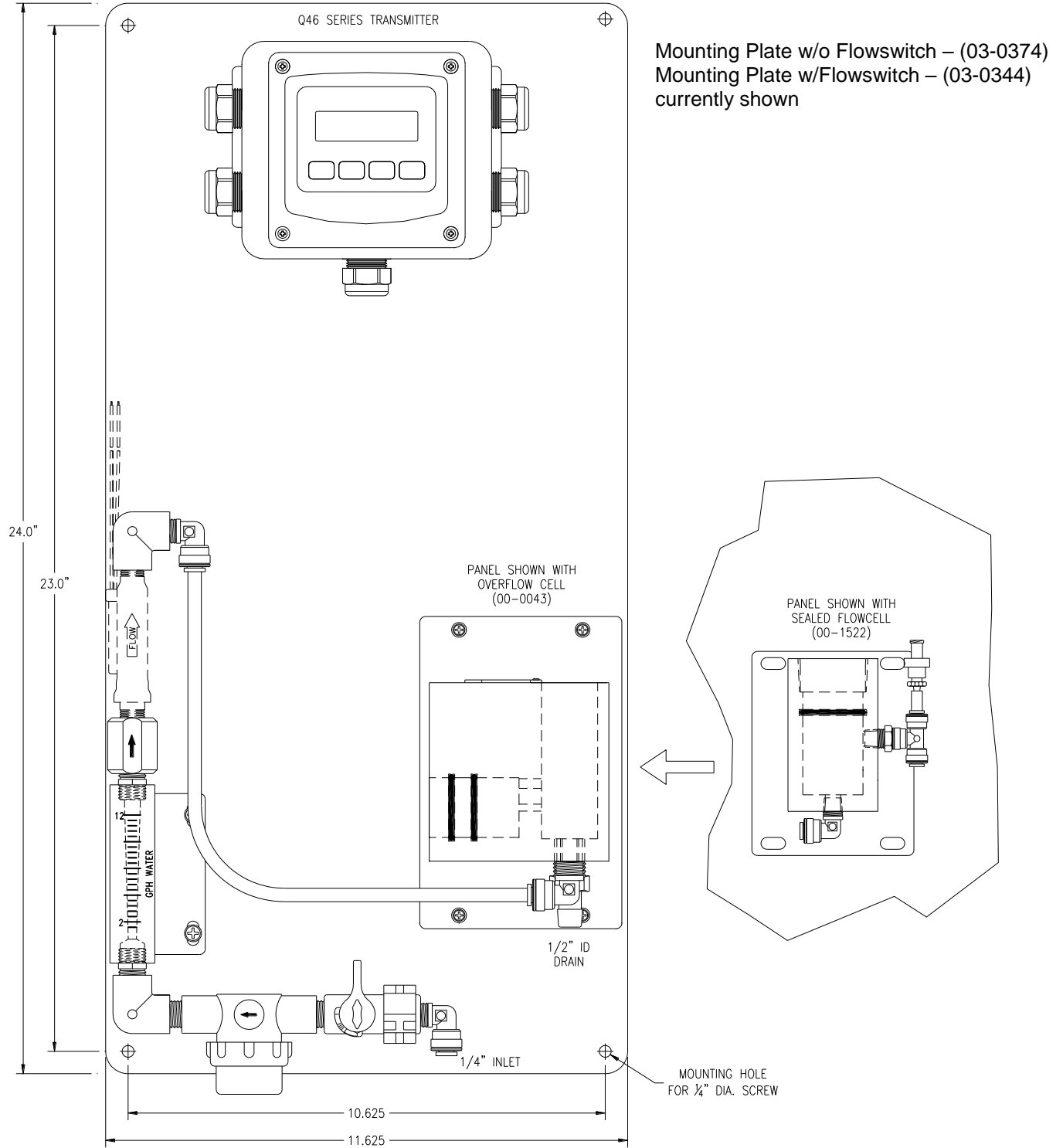

ATI-1224

ANALYZER DIMENSIONS (WALL MOUNT SHOWN)

Material: Polycarbonate
 Ratings: Nema 4X (IP-66)
 V-0 Fire Retardant

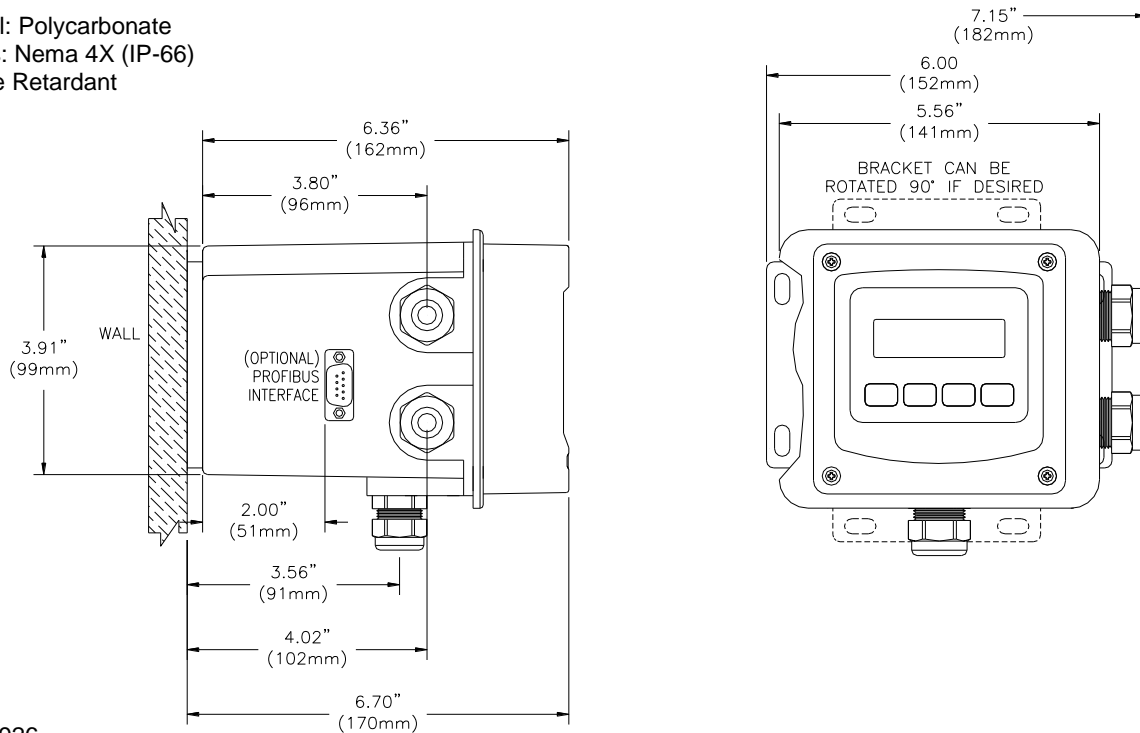

ATI-0926

JUNCTION BOX

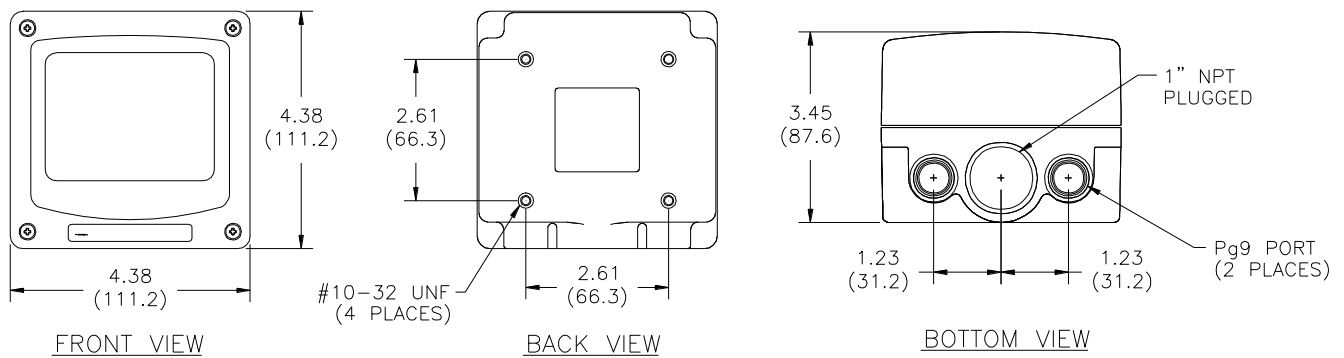

ATI-0655

PIPE MOUNTING

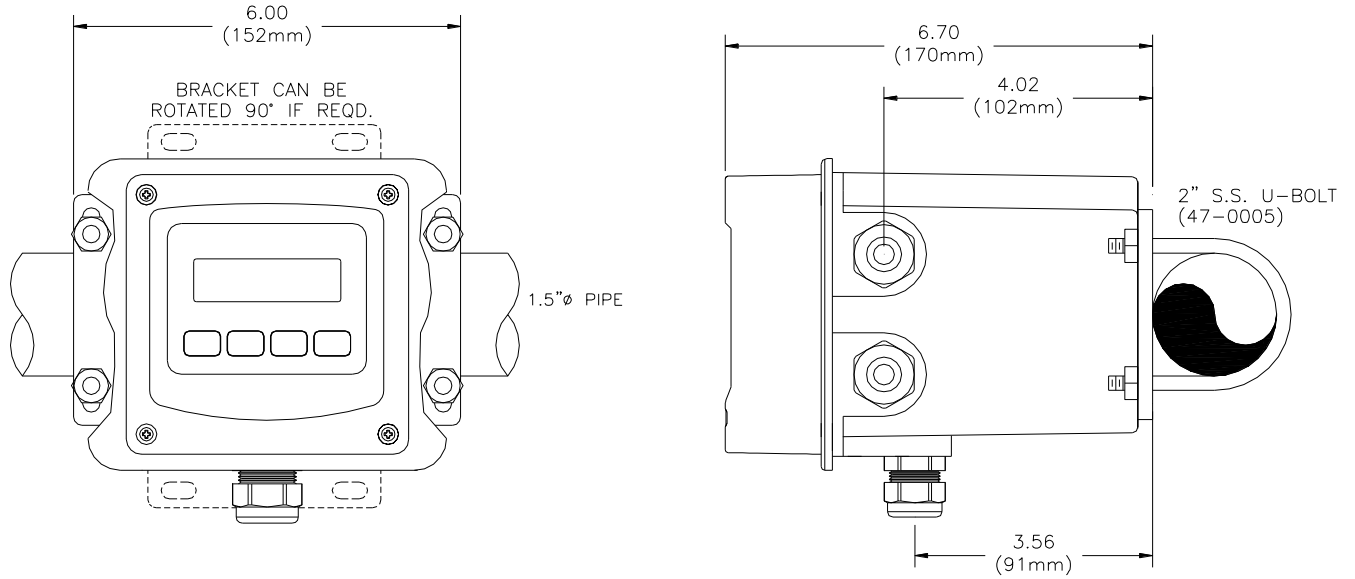

ATI-0927

PANEL MOUNTING

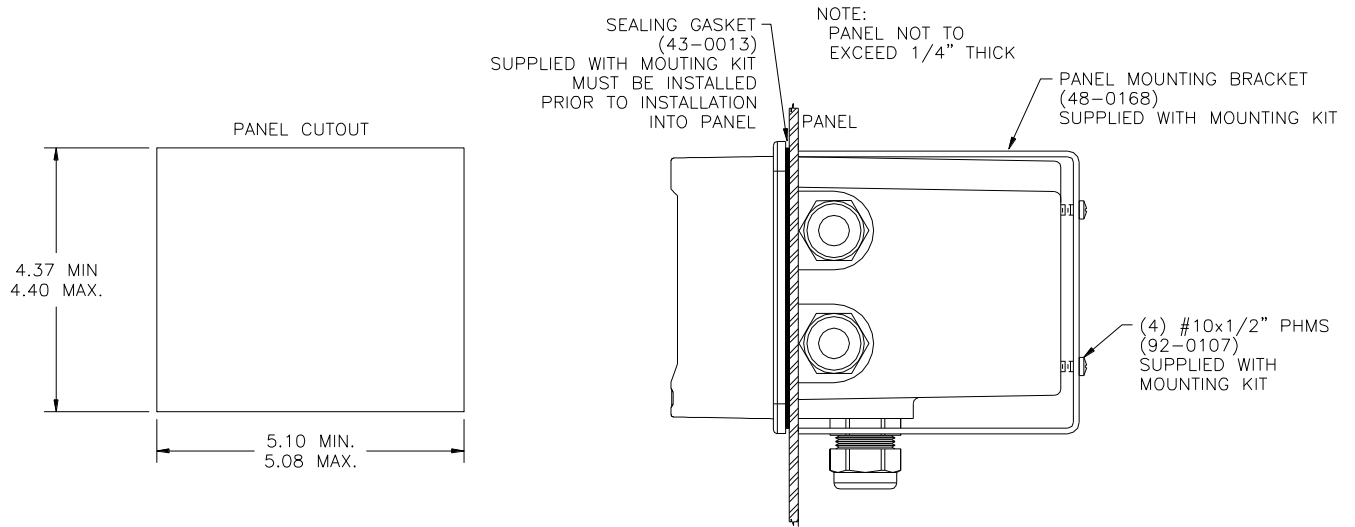

ATI-0928

FLOW SENSOR DIMENSIONS & OVERFLOW CELL INSTALLATION

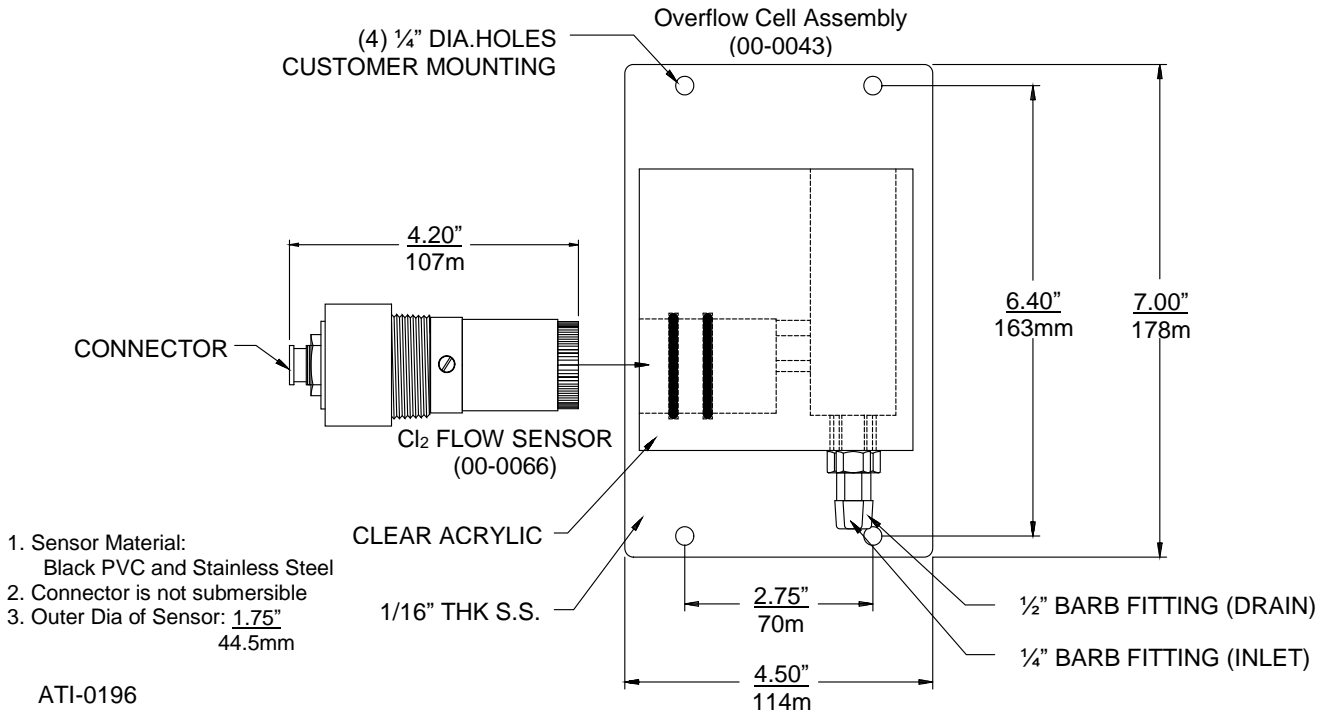

SEALED FLOWCELL ASSY DIMENSIONS (00-1522)

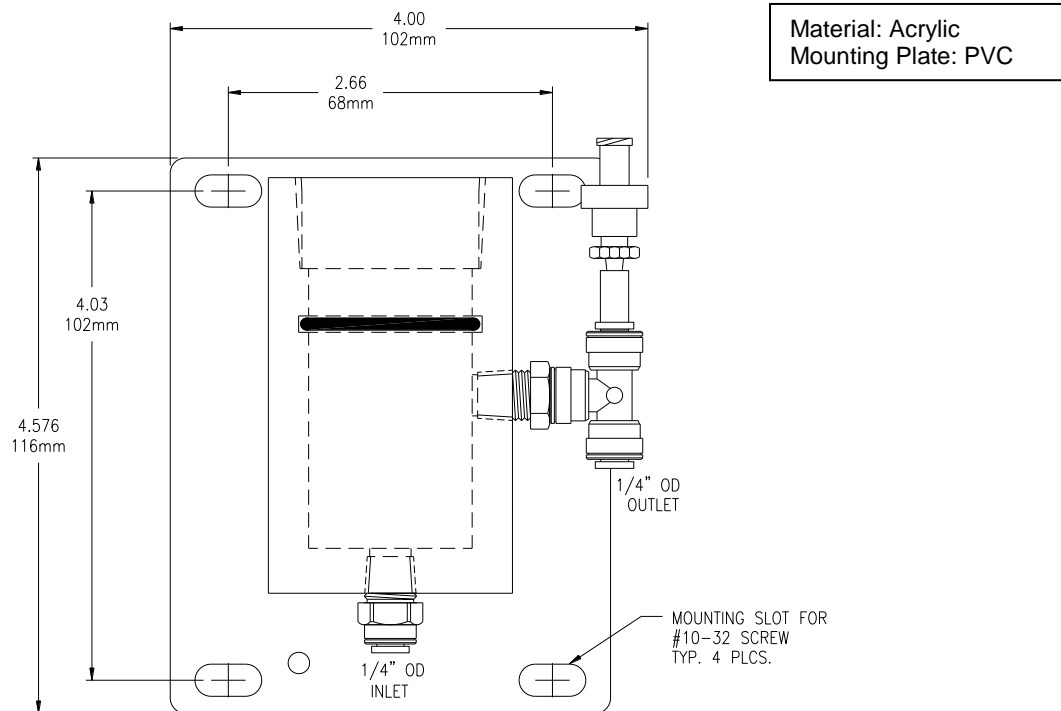

SUBMERSIBLE SENSOR DIMENSIONS

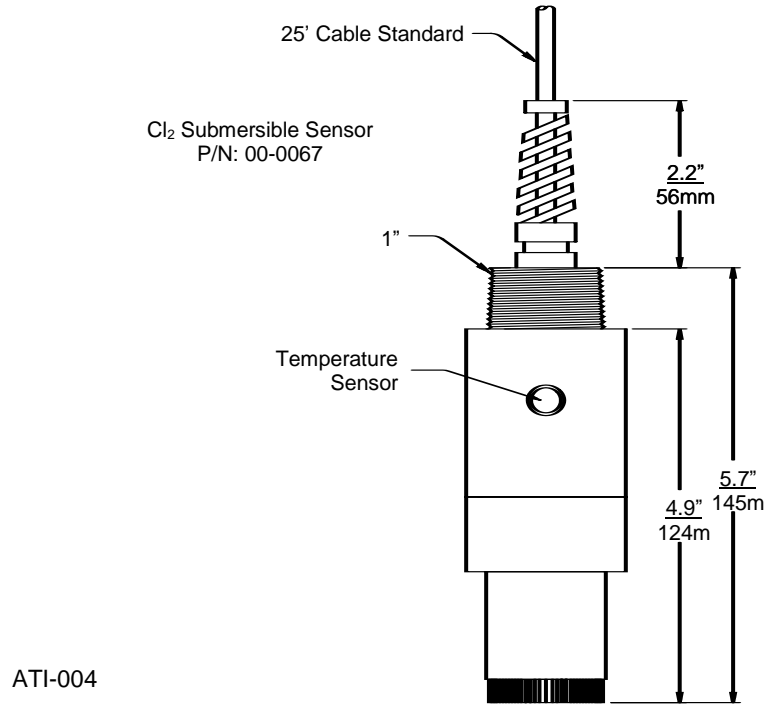

SUBMERSIBLE SENSOR DIMENSIONS

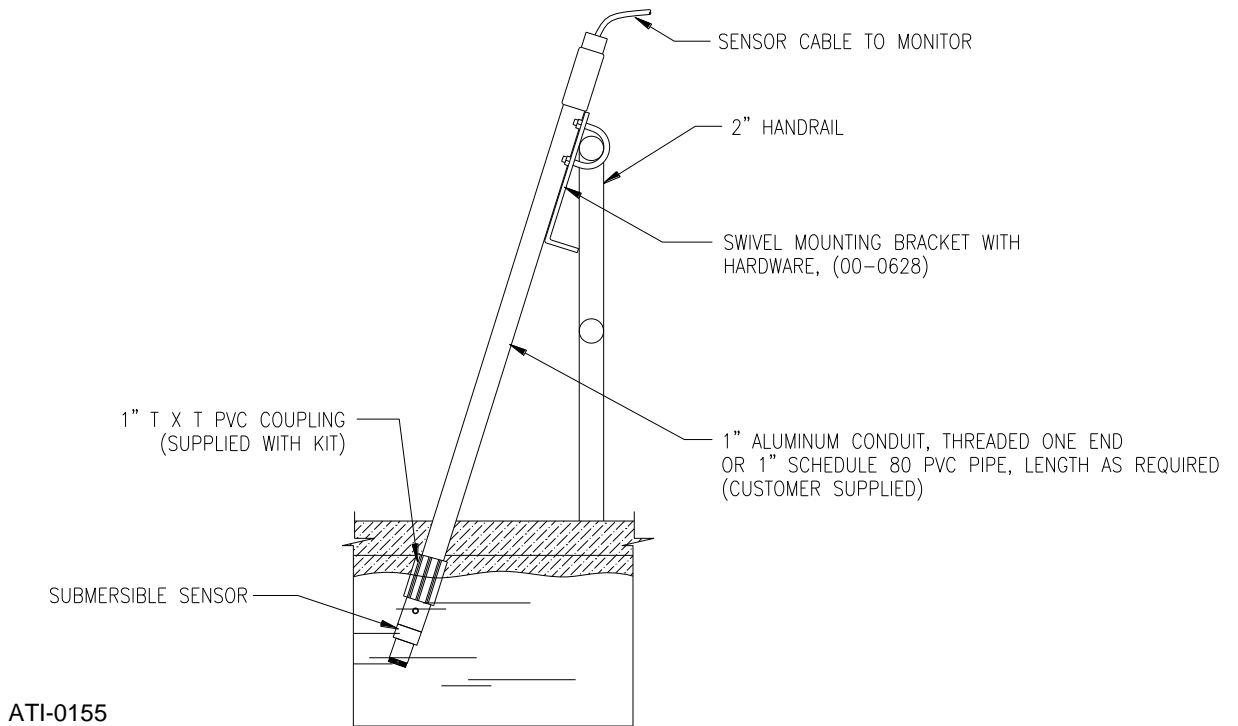

POWER, RELAY, AND OUTPUT CONNECTIONS

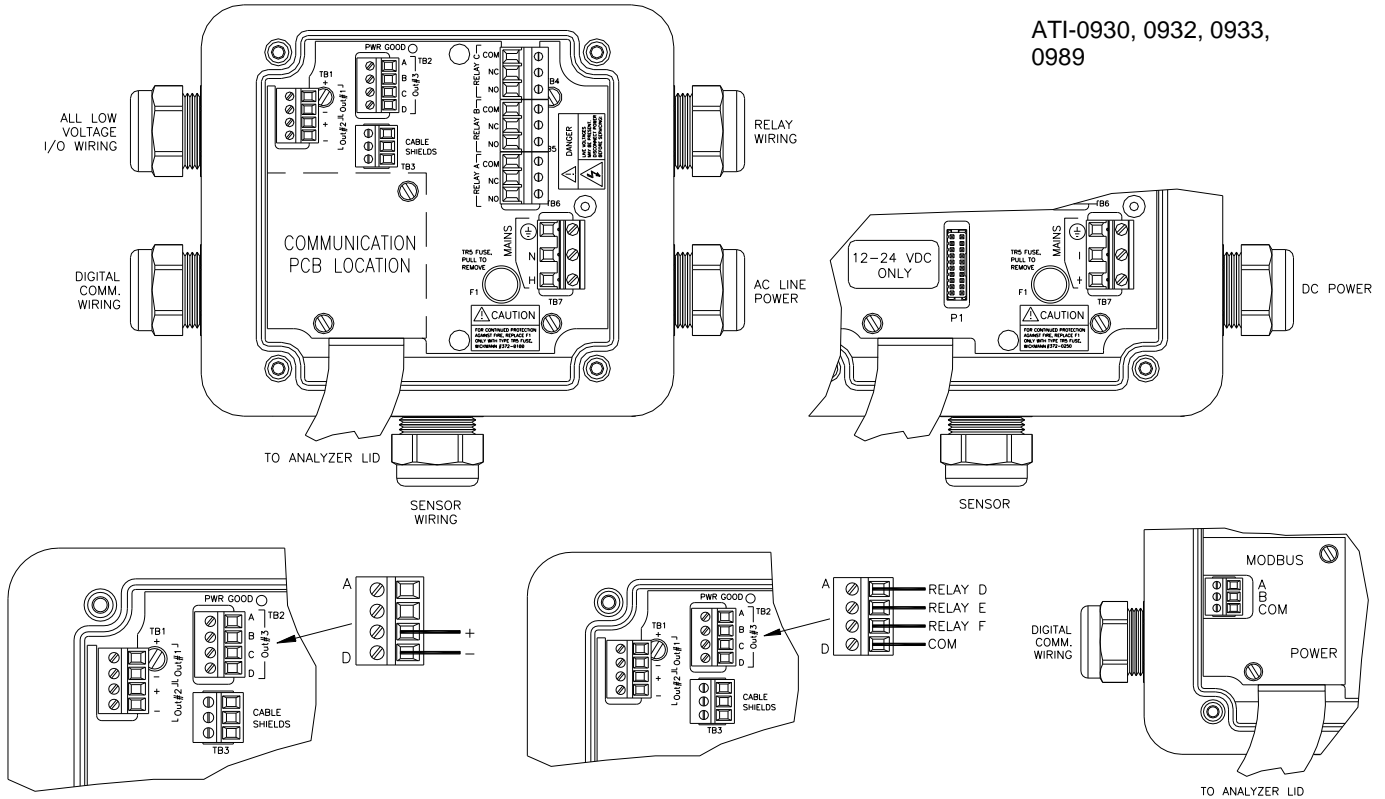

RELAY WIRING TB4,5,6 DETAIL

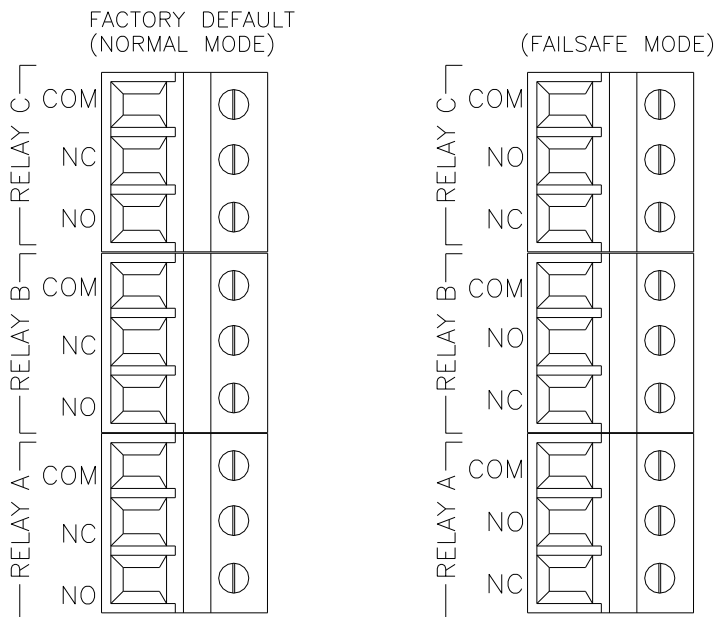

ELECTRICAL CONNECTIONS

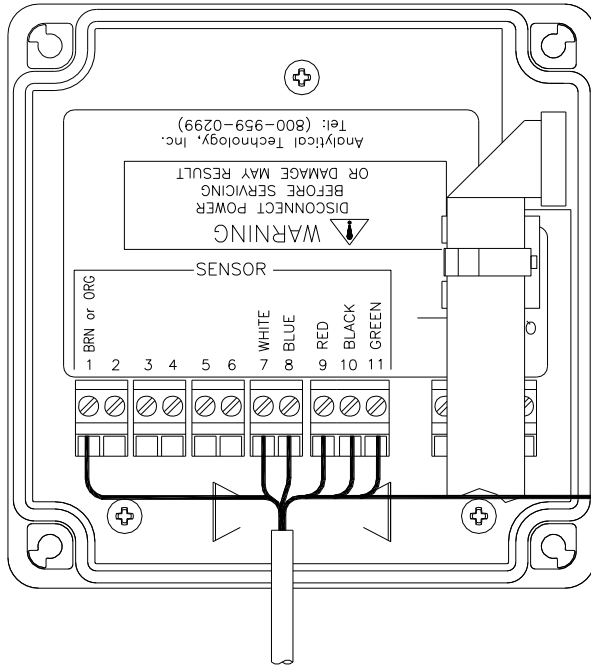

*CONNECT SHIELD TO T/B LABELED "CABLE SHIELDS" LOCATED ON P/S PCB INSIDE OF ENCLOSURE

ATI-1002

SENSOR CONNECTIONS – REMOTE JUNCTION BOX

