

Stainless steel master gauge open front or solid front

Model MGS

Nominal size: 150 mm (6") or 250 mm (10")

ASME B40.100 / EN 837-1 / IS-3624

Accuracy: Class 0.25 (0.25%)

Features

- Rugged stainless steel construction
- Protection IP65
- Usable to full scale
- Easy access for calibration
- Ambient temperature compensation
- Optional external Zero Adjustment

Ranges

-30 in. Hg ... 0 psi up to 0 ... 15,000 psi
 -1 ... 0 bar up to 0 ... 1000 bar & kg/cm²
 -100 ... 0 kPa up to 0 ... 100,000 kPa



Applications

Test benches
 Calibration laboratories
 Maintenance and repair shop

Technical specification	MGS	
Dial size in mm	150	250
Construction	Open front cylindrical case with snap action bayonet ring, optional Solid front for 150mm	
Measuring principle	Bourdon tube	
Range in kg/cm ² (or bar)	0.6 1 1.6 2.5 4 6 10 16 25 40 60 100 160 250 400 600 700 1000 -1/0 -1/0.6 -1/1.5 -1/3 -1/5 -1/9 -1/15 -1/24	
Overpressure limit	130 % F.S., short time.	
Pressure type	Gauge, vacuum and compound	
Process connection	1/4" 3/8" 1/2" BSP / NPT (M) , M20x1.5 (M) Others on request	
Connection location	Lower, back	
Material		
Pressure connection	Stainless steel 316, optional Monel	
Tube	Beryllium copper, optional Monel	
Case/bayonet ring	Stainless steel 304, optional 316L	
Window	Instrument glass, optional laminated safety glass, acrylic glass	
Dial	Aluminum, black markings on white background, with polished mirror band	
Pointer	Aluminum, black knife edge, optional - micrometer adjustment others on request	
Movement	High precision jewel bearing with temperature compensation	
Accuracy	Class 0.25 (0.25% F.S.)	
Permissible		
Ambient temperature	-40 ... 60 °C (-40 ... 140 °F)	
Medium temperature	Max. 100 °C (212 °F)	
Storage temperature	-40 ... 60 °C (-40 ... 140 °F)	
Effect	Automatic compensated	
Protection according	IP65	
Mounting	Standard stem, optional panel, bracket, surface or others on request	
Weight dry / filled in kg	0.87 / 1.68	1.99 / 4.09
Accessories, options	Valves	

All specifications are subject to change without notice.

General dimensions in mm

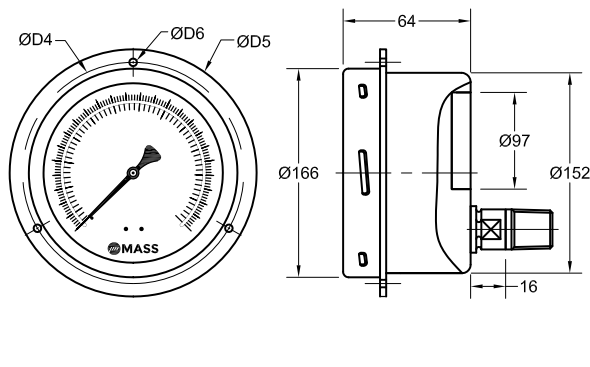
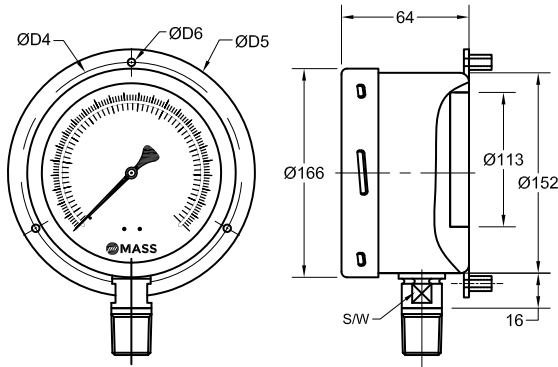

Lower Connection Surface Mounting with Solid Front

Back Connection Front Panel Mounting with Solid Front

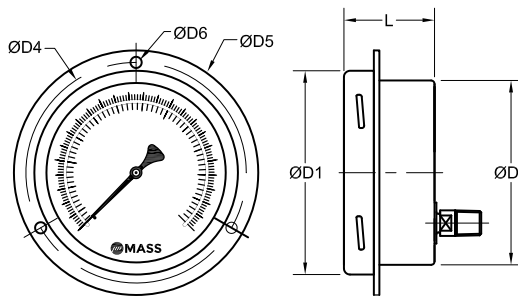
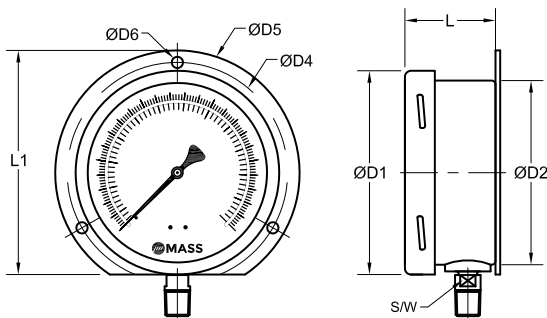

Lower Connection Surface Mounting with Open Front

Back Connection Front Panel Mounting with Open Front

DIAL SIZE	150	250
ØD1	166	265
ØD2	152	252
ØD4	168	276
ØD5	186	290
ØD6	6	7
L	49	53
L1	176	270
SW	17	17

Order information

Size	Type	System material	Execution	Process connection	Connection orientation	Range	Engineering units	Case material	Options
(150) 150mm	MGS	(A) Socket 316, Tube beryllium copper	(=) IP65	(04) 1/2" NPT (M)	(L) Lower	-1/ 0	kg/cm ² (bar)	(=) Standard	(NH) Tagging wired
(250) 250mm				(03) 3/8" NPT (M)		(B) Back			
				(02) 1/4" NPT (M)		-1/ 1.5		(YW) Case material 316L	(DA) Dial Marking
		(M) Socket & Tube Monel		(15) 1/2" BSP (M)		-1/ 3			(CS) Dual Scale
				(14) 3/8" BSP (M)		-1/ 5			(OF) Oil free
				(13) 1/4" BSP (M)		-1/ 9			(PD) Acrylic glass
				(16) M20x1.5 (M)		-1/ 15			(MP) Micrometer pointer
						0/ 0.6			(EZ) External Zero adjustment ¹⁾
						0/ 1			(SG) Safety glass
						0/ 1.6			(FX) Front panel
						0/ 2.5			(FW) Surface plate
					0/ 4			(UF) U-clamp ²⁾	
					0/ 6			(SF) Solid front ¹⁾	
					0/ 10				
					0/ 16				
					0/ 25				
					0/ 40				
					0/ 60				
					0/ 100				
					0/ 160				
					0/ 250				
					0/ 400				
					0/ 600				
					0/ 700				
					0/ 1000				
						Equivalent ranges in kPa, MPa, psi, bar and others units available			

1) Not for 250mm 2) not for solid front (SF)

How to order

Size	Type	System material	Execution	Process connection	Connection orientation	Range	Engineering unit	Case material	Option
150	MGS	A	=	04	L	0/16	KG/CM ²	=	NH

Precision Mass Products Pvt. Ltd.

Plot No.: 2306, G.I.D.C. Chhatral, Ta: Kalol, Dist.: Gandhinagar, Chhatral -382729, Gujarat, India.

Telephone: +91-2764 233681/82/83

Email: sales@precisionmass.com

Fax: +91-2764-233440

www.precisionmass.com

• North Zone : sales.delhi@precisionmass.com

• East zone : sales.kolkata@precisionmass.com

• West zone : sales.mumbai@precisionmass.com

• South zone : sales.chennai@precisionmass.com