

Model Q45H/62

2-Wire Free Chlorine Transmitter

Home Office

Analytical Technology, Inc.
6 Iron Bridge Drive
Collegeville, PA 19426

Ph: 800-959-0299
610-917-0991

Fax: 610-917-0992

Email: sales@analyticaltechnology.com

European Office

ATI (UK) Limited
Unit 1 & 2 Gatehead Business Park
Delph New Road, Delph
Saddleworth OL3 5DE

Ph: +44 (0)1457-873-318

Fax: + 44 (0)1457-874-468

Email: sales@atiuk.com

PRODUCT WARRANTY

Analytical Technology, Inc. (Manufacturer) warrants to the Customer that if any part(s) of the Manufacturer's equipment proves to be defective in materials or workmanship within the earlier of 18 months of the date of shipment or 12 months of the date of start-up, such defective parts will be repaired or replaced free of charge. Inspection and repairs to products thought to be defective within the warranty period will be completed at the Manufacturer's facilities in Collegetown, PA. Products on which warranty repairs are required shall be shipped freight prepaid to the Manufacturer. The product(s) will be returned freight prepaid and allowed if it is determined by the manufacturer that the part(s) failed due to defective materials or workmanship.

This warranty does not cover consumable items, batteries, or wear items subject to periodic replacement including lamps and fuses.

Gas sensors carry a 12 months from date of shipment warranty and are subject to inspection for evidence of misuse, abuse, alteration, improper storage, or extended exposure to excessive gas concentrations. Should inspection indicate that sensors have failed due to any of the above, the warranty shall not apply.

The Manufacturer assumes no liability for consequential damages of any kind, and the buyer by acceptance of this equipment will assume all liability for the consequences of its use or misuse by the Customer, his employees, or others. A defect within the meaning of this warranty is any part of any piece of a Manufacturer's product which shall, when such part is capable of being renewed, repaired, or replaced, operate to condemn such piece of equipment.

This warranty is in lieu of all other warranties (including without limiting the generality of the foregoing warranties of merchantability and fitness for a particular purpose), guarantees, obligations or liabilities expressed or implied by the Manufacturer or its representatives and by statute or rule of law.

This warranty is void if the Manufacturer's product(s) has been subject to misuse or abuse, or has not been operated or stored in accordance with instructions, or if the serial number has been removed.

Analytical Technology, Inc. makes no other warranty expressed or implied except as stated above

Table of Contents

PART 1 - INTRODUCTION	5	PART 7 – CALIBRATION.....	47
1.1 GENERAL	5	7.1 CHLORINE CALIBRATION.....	47
1.2 STANDARD SYSTEM.....	6	7.11 CHLORINE ZERO CAL	47
1.3 FEATURES	9	7.12 CHLORINE SPAN CAL	48
1.4 Q45H/62 SYSTEM SPECIFICATIONS.....	10	7.2 TEMPERATURE CALIBRATION	50
1.5 Q45H PERFORMANCE SPECIFICATIONS	11	7.3 PH CALIBRATION	51
PART 2 – ANALYZER MOUNTING	12	7.31 TWO-POINT PH CAL	52
2.1 GENERAL	12	7.32 ONE-POINT PH CAL.....	53
2.2 WALL OR PIPE MOUNT.....	14	7.4 ADJUSTING PH COMPENSATION CURVE	54
PART 3 – SENSOR/FLOWCELL MOUNTING	16	7.41 MODIFYING PH CORRECTION VALUES	54
3.1 GENERAL	16	7.42 PH CORRECTION – TABLE MODIFICATION EXAMPLE.....	56
3.2 CONSTANT-HEAD FLOWCELL	16	7.43 STORING MODIFIED TABLE.....	57
3.3 SEALED FLOWCELL	17	PART 8 – PID CONTROLLER DETAILS	58
PART 4 – ELECTRICAL INSTALLATION	19	8.1 PID DESCRIPTION	58
4.1 GENERAL	19	8.2 PID ALGORITHM	58
4.2 TWO-WIRE	19	8.3 CLASSICAL PID TUNING	60
4.21 LOAD DRIVE	21	8.4 MANUAL PID OVERRIDE CONTROL	61
4.3 SENSOR WIRING	22	8.5 COMMON PID PITFALLS	61
4.4 DIRECT SENSOR CONNECTION	22	PART 9 – SYSTEM MAINTENANCE	63
4.5 JUNCTION BOX CONNECTION	23	9.1 GENERAL	63
4.7 OPTIONAL PH COMPENSATION INPUT	24	9.2 ANALYZER MAINTENANCE	63
PART 5 – SENSOR ASSEMBLY	27	9.3 SENSOR MAINTENANCE	63
5.1 CHLORINE SENSOR PREPARATION	27	9.4 SENSOR ACID CLEANING	64
5.2 OPTIONAL PH SENSORS	28	9.5 Q22P SENSOR CLEANING	65
PART 6 – CONFIGURATION	29	9.6 REPLACING THE SALTBRIDGE AND REFERENCE BUFFER SOLUTION.....	66
6.1 USER INTERFACE	29	9.7 FLOW CELL MAINTENANCE.....	67
6.11 KEYS	30	PART 10 – TROUBLESHOOTING	68
6.12 DISPLAY.....	30	10.1 GENERAL	68
6.2 SOFTWARE	32	10.2 EXTERNAL SOURCES OF PROBLEMS	68
6.21 SOFTWARE NAVIGATION	32	10.3 ANALYZER TESTS	70
6.22 MEASURE MENU [MEASURE]	35	10.4 DISPLAY MESSAGES	71
6.23 CALIBRATION MENU [CAL]	36	10.5 SENSOR TESTS	73
6.24 CONFIGURATION MENU [CONFIG].....	37	10.6 TROUBLESHOOTING (Q22P SENSOR)	75
6.25 CONTROL MENU [CONTROL].....	41	SPARE PARTS.....	76
6.26 DIAGNOSTICS MENU [DIAG]	43	SPARE PARTS (CONT'D)	77

TABLE OF FIGURES

FIGURE 1 - TYPICAL CHLORINE MONITORING SYSTEM.....	6
FIGURE 2 - CHLORINE SYSTEM WITH CONVENTIONAL PH STYLE SENSOR.....	7
FIGURE 3 - SEALED FLOWCELL ASSEMBLIES WITH FLOW CONTROL.....	8
FIGURE 4 - Q45 ENCLOSURE DIMENSIONS, 2-WIRE & EXTERNAL POWER.....	13
FIGURE 5 - WALL OR PIPE MOUNT BRACKET.....	14
FIGURE 6 - WALL MOUNTING DIAGRAM.....	15
FIGURE 7 - PIPE MOUNTING DIAGRAM.....	15
FIGURE 8 - CONSTANT HEAD FLOWCELL DETAILS.....	16
FIGURE 9 - SEALED CL ₂ FLOWCELL DETAILS.....	17
FIGURE 10 - SEALED PH FLOWCELL DETAILS.....	18
FIGURE 11 - LOOP POWER SENSOR CONNECTION.....	20
FIGURE 12 - SENSOR CABLE PREPARATION.....	22
FIGURE 13 - JUNCTION BOX INTERCONNECT WIRING.....	23
FIGURE 14 - OPTIONAL PH COMPENSATOR CONNECTION.....	25
FIGURE 15 - OPTIONAL PH COMPENSATOR CONNECTION W/JUNCTION BOX.....	26
FIGURE 16 - CHLORINE SENSOR ASSEMBLY.....	27
FIGURE 17 - USER INTERFACE.....	29
FIGURE 18 - SOFTWARE MAP.....	34
FIGURE 19 - AUTOMATIC PH BUFFER TABLES.....	40
FIGURE 20 - TYPICAL FREE CHLORINE RESPONSE TO CHANGE IN PH.....	56
FIGURE 21 - Q45H ISA (IDEAL) PID EQUATION.....	59
FIGURE 22 - REPLACING THE SALTBRIDGE AND REFERENCE BUFFER.....	66
FIGURE 23 - Q45H DISPLAY MESSAGES.....	71
FIGURE 24 - Q45H DISPLAY MESSAGES (CONTINUED).....	72
FIGURE 25 - PT100 RTD TABLE.....	74

Part 1 - Introduction

1.1 General

The Model Q45H/62 is a versatile on-line monitoring system designed for the continuous measurement of free chlorine in solution. The full scale operating range of the system is user selectable for 0-200.0 ppb, 0-2.000 ppm, 0-20.00 PPM, or 0-200.0 ppm, and the sensing system will operate on water streams with temperatures from 0 to 55°C. The Q45H/62 Free Chlorine Measurement System is well suited for potable water treatment plants, cooling water, reverse osmosis membrane protection, or activated carbon filter break-through detection.

The basic sensing element used in the free chlorine monitor is a polarographic membrane sensor which measures chlorine directly. Water simply flows past the sensor and directly to drain, with the flow rate and pressure across the sensor controlled by a constant head flow cell assembly. The chlorine measurement does not alter the sample or add any chemicals to the sample stream, so the water flow can return to the system if desired.

Q45H/62 Monitors are available in three electronic versions, a loop-powered 2-wire transmitter, a dual "AA" battery operated portable unit with two voltage outputs, and a 5-17 VDC Externally powered unit with two voltage outputs. This manual refers to the Loop-Powered 2-wire transmitter version.

In addition to normal chlorine measurement, the Q45H/62 is also available with an optional pH input which provides a two-parameter monitoring system. Both free chlorine and pH are displayed simultaneously, and the free chlorine value is automatically compensated for pH changes. On battery operated units, analog outputs are available for BOTH free chlorine and pH.

1.2 Standard System

The standard model Q45H/62 system includes three main components, the Q45H analyzer, a constant head flow cell, and a free chlorine sensor. A sealed flowcell is also available for applications where sample flowrate and pressure can be carefully controlled. Figure 1 shows a typical installation including the optional 07-0096 pH sensor.

For connection of the sensor to the electronics, a 25' cable is supplied. An additional 100 feet of interconnect cable may be added using #07-0100 junction box. All required spare parts are also provided with the basic system, including spare membranes, electrolyte, o-rings, and any special hardware.

Note that standard 25 ft. sensor cables for both chlorine and optional pH sensors can be cut to a shorter length. Cutting the cables will not affect performance, and elimination of extra cable can sometimes eliminate electrical noise pickup through the cables.

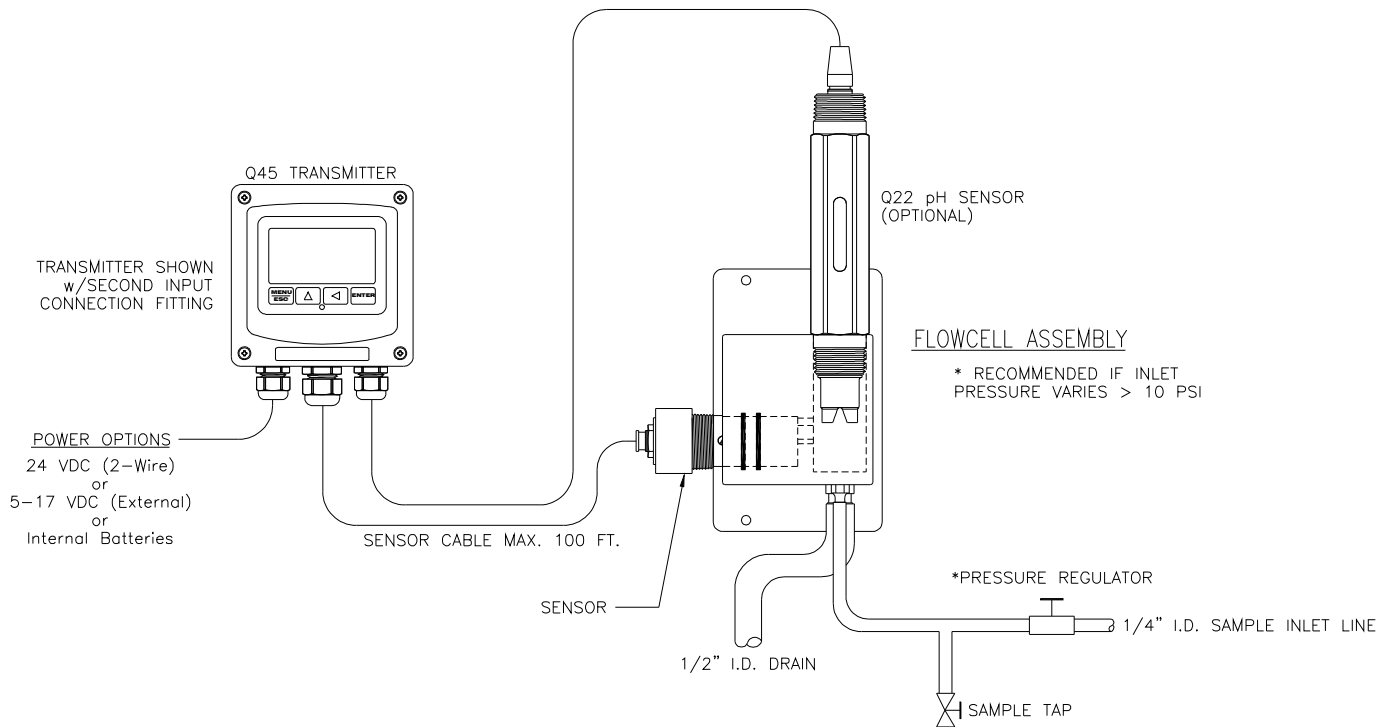

Figure 1 - Typical Chlorine Monitoring System

Figure 2 below shows the same standard flowcell assembly and chlorine sensor along with the conventional type pH sensor. A special adapter is required to hold the pH sensor in its proper location in the flowcell inlet chamber.

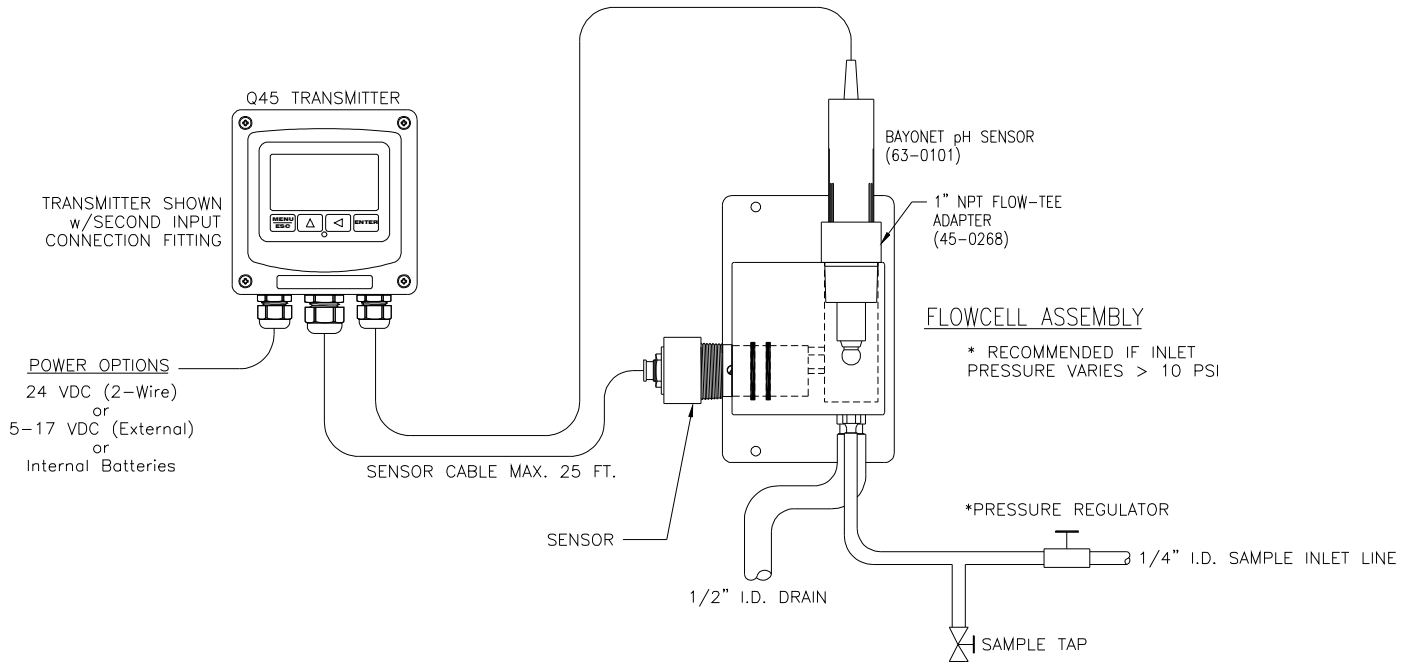

Figure 2 - Chlorine System with Conventional pH Style Sensor

Figure 3 below shows an installation using a 00-1522 sealed flowcell for the chlorine sensor and a 00-1527 sealed flowcell for the pH sensor. This type of installation requires careful flow control. We recommend the use of our 03-0372 flow control assembly when using sealed flowcells. This assembly consists of an in-line filter and a fixed-flow regulator which will maintain a constant 400 cc/min flowrate through the system. This flow will be maintained so long as inlet pressures are between 5 and 125 PSIG. The in-line filter is used mainly to protect the flow control element against larger particles that might cause plugging of the device.

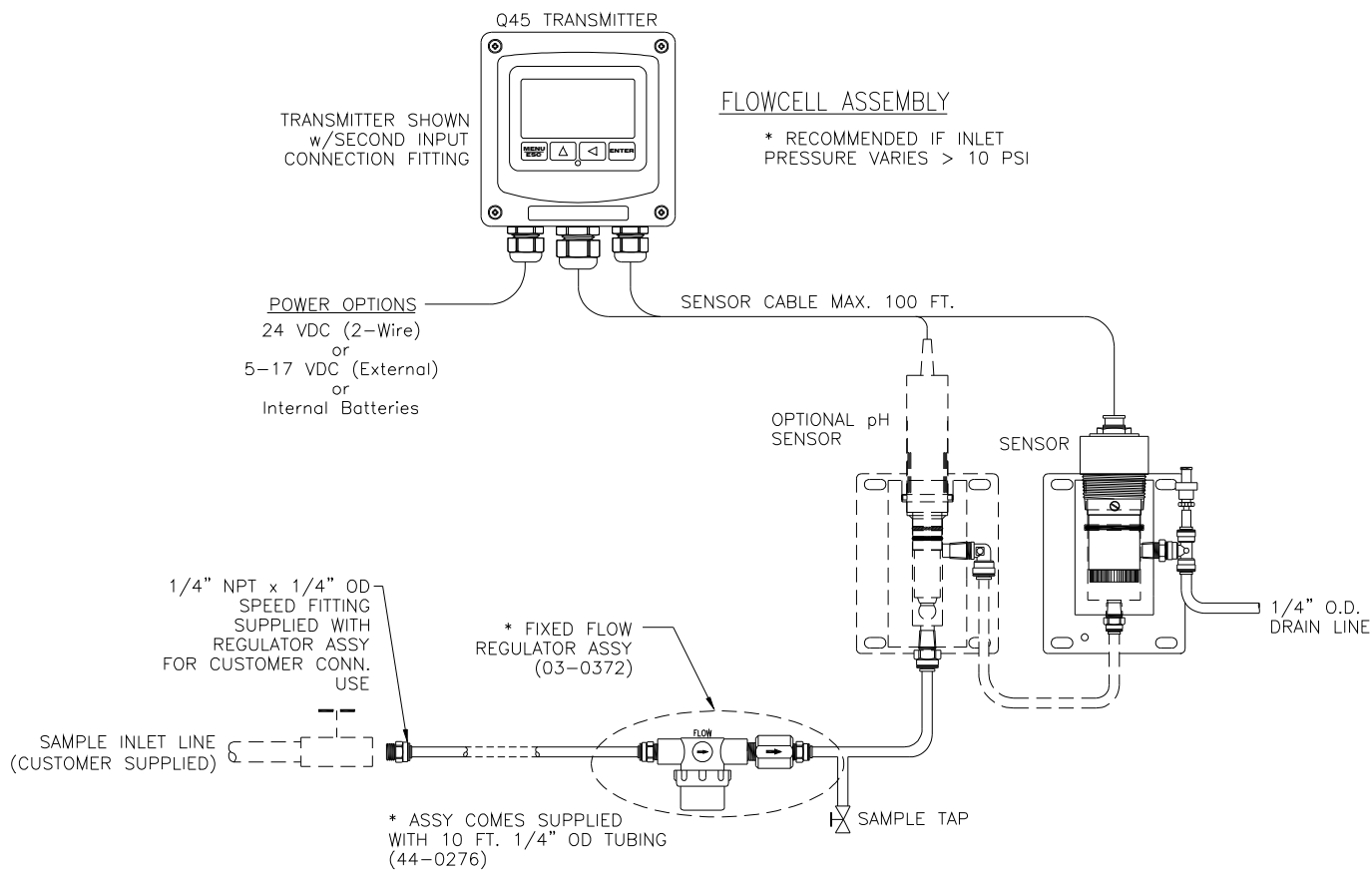

Figure 3 - Sealed Flowcell Assemblies with Flow Control

1.3 Features

- Standard Q45H/62 transmitters are fully isolated, loop powered instruments for 2-wire DC applications.
- High accuracy, high sensitivity system, measures from 1 ppb to 200.0 ppm through 4 internal automatic ranges. User ranges of 200.0 ppb, 2.000 ppm, 20.00 ppm, or 200.0 ppm.
- Output Hold, Output Simulate, Output Alarm, and Output Delay Functions. All forced changes in output condition include bumpless transfer to provide gradual return to on-line signal levels and to avoid system control shocks on both analog outputs.
- Selectable PID controller on main analog output. PID controller can operate with instrument configured as loop-power transmitter. PID includes manual operation feature, and diagnostic “stuck-controller” timer feature for alarm output of control problems. Not applicable to battery or external DC powered units.
- Selectable automatic pH compensation feature. Enables active pH compensation of free chlorine readings – requiring no pumps or buffers to maintain a constant pH level. The pH reading can also be sent to one of the analog outputs for complete pH + chlorine monitoring. The pH correction can be done using ATI’s optional pH sensor or using an input signal of 0.4-2.0 VDC (4-20 mA across a 100 ohm resistor) from another pH monitor. Input from another monitor requires the use of a loop isolator
- Large, high contrast, custom LCD display with LED back light provides excellent readability in any light conditions. The secondary line of display utilizes 5x7 dot matrix characters for clear message display. Two of four measured parameters may be on the display simultaneously.
- Diagnostic messages provide a clear description of any problem with no confusing error codes to look up. Messages are also included for diagnosing calibration problems.
- Quick and easy one-point calibration method and sensor zero-cal. To provide high accuracy, all calibration methods include stability monitors that check temperature and main parameter stability before accepting data.
- High accuracy three-wire Pt100 temperature input. Temperature element can be user calibrated.
- Security lock feature to prevent unauthorized tampering with transmitter settings. All settings can be viewed while locked, but they cannot be changed.

1.4 Q45H/62 System Specifications

Displayed Parameters	Main input, 0.1 ppb (0.0001 ppm) to 200.0 ppm Sensor temperature, -10.0 to 55.0 °C (23 to 131 °F) Sensor Current, 0.0–999.9 nA, 0.000 to 99.99 uA Loop current, 4.00 to 20.00 mA Sensor slope/offset Model number and software version PID Controller Status Optional pH Input value. 0.00 to 14.00 pH
Main Parameter Ranges	Manual selection of one of the following ranges, 0.000 to 200.0 ppb 0.0 to 2.000 ppm 0.00 to 20.00 ppm 0.00 to 200.0 ppm
Display	0.75" (19.1 mm) high 4-digit main display with sign 12-digit secondary display, 0.3" (7.6 mm) 5x7 dot matrix.
Keypad	4-key membrane type with tactile feedback, polycarbonate with UV coating
Weight	1 lb. (0.45 kg)
Ambient Temperature	Analyzer Service, -20 to 60 °C (-4 to 140 °F) Sensor Service, -5 to 55°C (23 to 131 °F) Storage, -5 to 70 °C (-22 to 158 °F)
Ambient Humidity	0 to 95%, indoor/outdoor use, non-condensing to rated ambient temperature range
Altitude	Maximum 2000 m (6562 Ft.)
Electrical Certification	Ordinary Location, cCSAus (CSA and UL standards - both approved by CSA), pollution degree 2, installation category 2
EMI/RFI Influence	Designed to EN 61326-1
Output Isolation	600 V galvanic isolation
Temperature Input	Pt100 RTD, 3-wire type
Sensor	2-electrode polarographic membraned sensor for direct measurement of chlorine,

Sensor Materials	PVC and stainless steel
Sensor Cable	25 ft. (7.5 meter) cable with 6-pin plug.
Max. Sensor-to-Analyzer Distance	100 feet (30.5 meters), with junction box
Optional pH Compensation	Accepts standard combination or Q22P pH Sensors
Input Flow Cell	Constant head overflow, clear cast acrylic, 7-30 GPH, 15 GPH recommended, inlet is ¼" hose barb at 1/8" MNPT, outlet is ½" hose barb at 3/8" MNPT
Power	16-35 VDC for 2-wire transmitter unit
Enclosure:	NEMA 4X, polycarbonate, stainless steel hardware, weatherproof and corrosion resistant, HWD: 4.4" (112 mm) x 4.4" (112 mm) x 3.5" (89 mm)
Mounting Options	Wall or pipe mount bracket standard. Bracket suitable for either 1.5" or 2" I.D. U-Bolts for pipe mounting.
Conduit Openings	Two PG-9 openings with gland seals
DC Cable Type	Belden twisted-pair, shielded, 22 gauge or larger

1.5 Q45H Performance Specifications

Accuracy	0.5% of selected range or 0.02 PPM
Repeatability	0.3% of selected range or 0.01 PPM
Sensitivity	0.05% of selected range
Non-linearity	0.1% of selected range
Warm-up Time	3 seconds to rated performance (electronics only)
Supply Voltage Effects	± 0.05% span
Instrument Response Time	60 seconds to 90% of step input at lowest damping



Equipment bearing this marking may not be discarded by traditional methods in the European community after August 12 2005 per EU Directive 2002/96/EC. End users must return old equipment to the manufacturer for proper disposal.

Part 2 – Analyzer Mounting

2.1 General

All Q45 Series instruments offer maximum mounting flexibility. A bracket is included with each unit that allows mounting to walls or pipes. In all cases, choose a location that is readily accessible for calibrations. Also consider that it may be necessary to utilize a location where solutions can be used during the calibration process. To take full advantage of the high contrast display, mount the instrument in a location where the display can be viewed from various angles and long distances.

Locate the instrument in close proximity to the point of sensor installation - this will allow easy access during calibration. The sensor-to-instrument distance should not exceed 100 feet. To maximize signal-to-noise ratio however, work with the shortest sensor cable possible. The standard cable length of the chlorine sensor is 25 feet.

Refer to Figures 4 and 6 for mounting diagrams for each option.

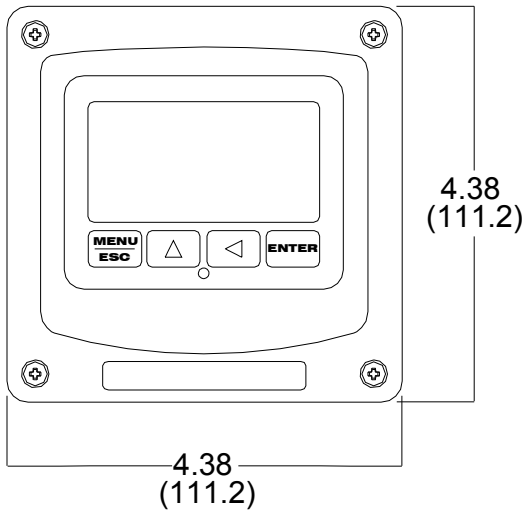

FRONT VIEW

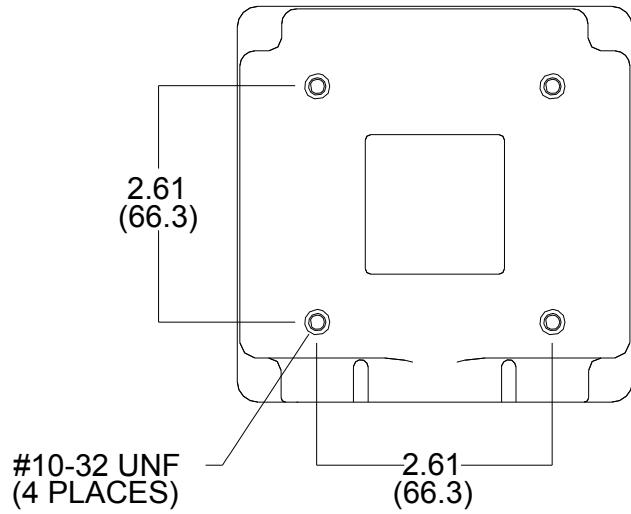

BACK VIEW

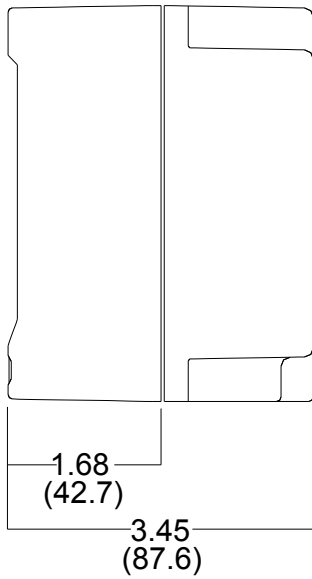

SIDE VIEW

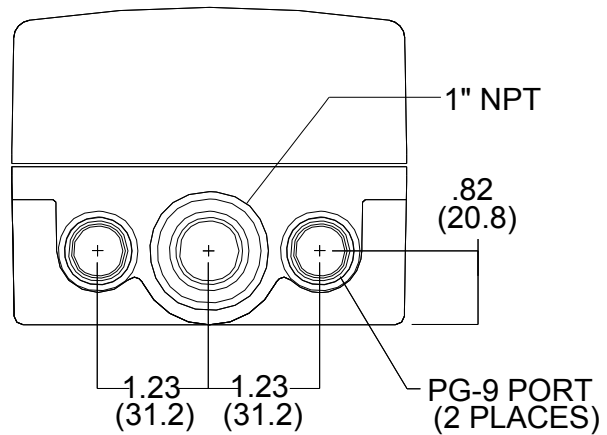

BOTTOM VIEW

Figure 4 - Q45 Enclosure Dimensions, 2-Wire & External Power

2.2 Wall or Pipe Mount

A PVC mounting bracket with attachment screws is supplied with each transmitter (see **Error! Reference source not found.** for dimensions). The multi-purpose bracket is attached to the rear of the enclosure using the four flat head screws. The instrument is then attached to the wall using the four outer mounting holes in the bracket. These holes are slotted to accommodate two sizes of u-bolt that may be used to pipe mount the unit. Slots will accommodate u-bolts designed for 1½" or 2" pipe. The actual center to center dimensions for the u-bolts are shown in the drawing. Note that these slots are for u-bolts with ¼-20 threads. The 1½" pipe u-bolt (2" I.D. clearance) is available from ATI in type 304 stainless steel under part number 47-0005

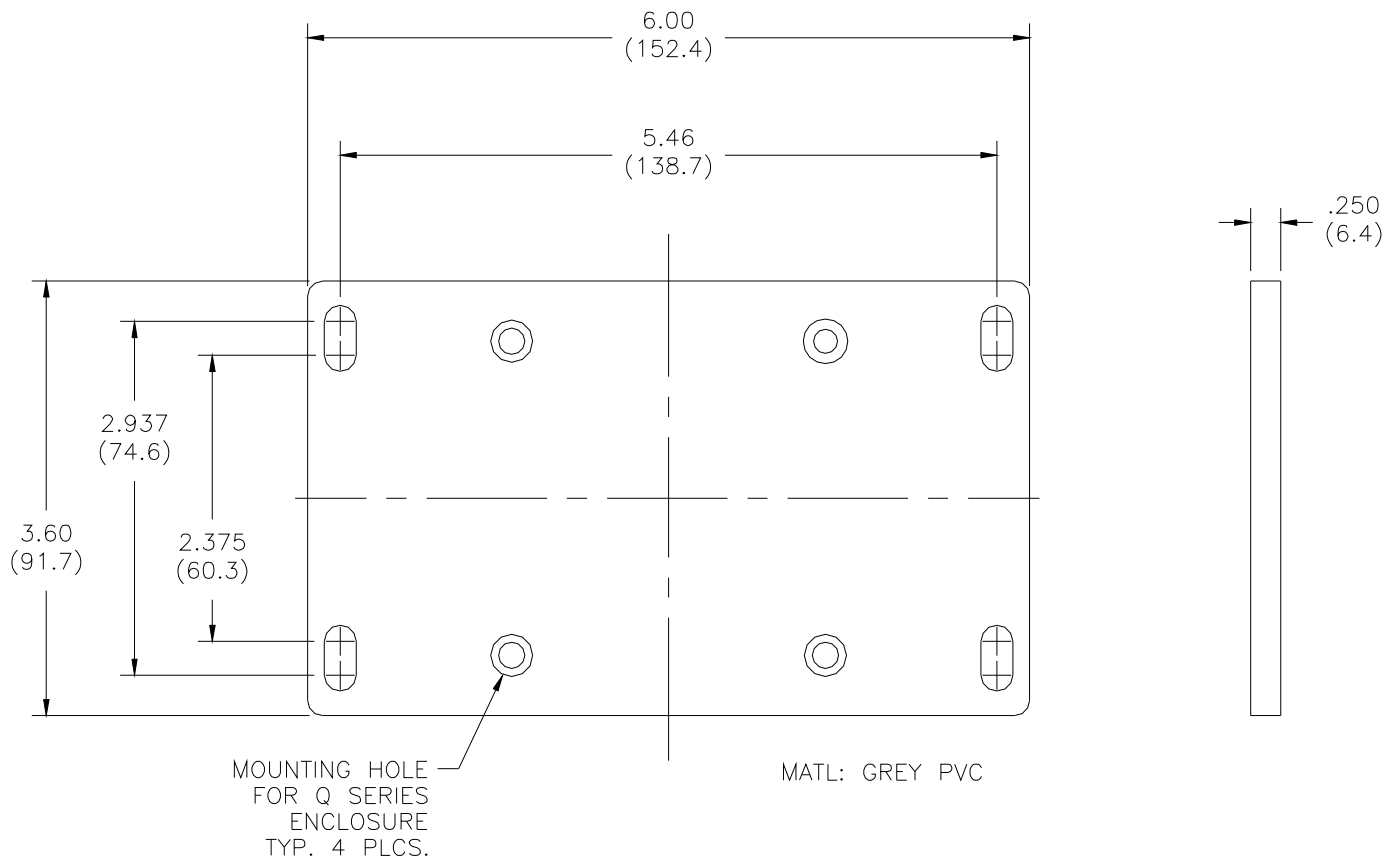

Figure 5 - Wall or Pipe Mount Bracket

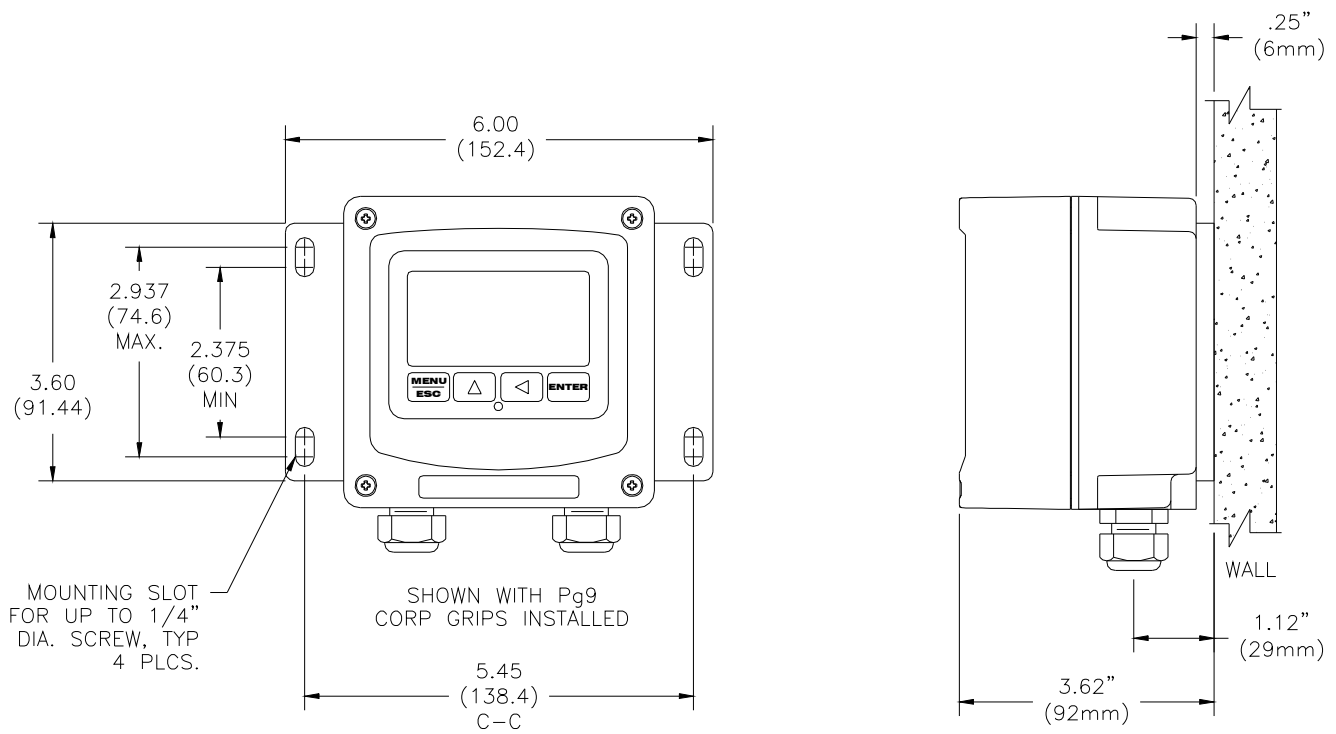

Figure 6 - Wall Mounting Diagram

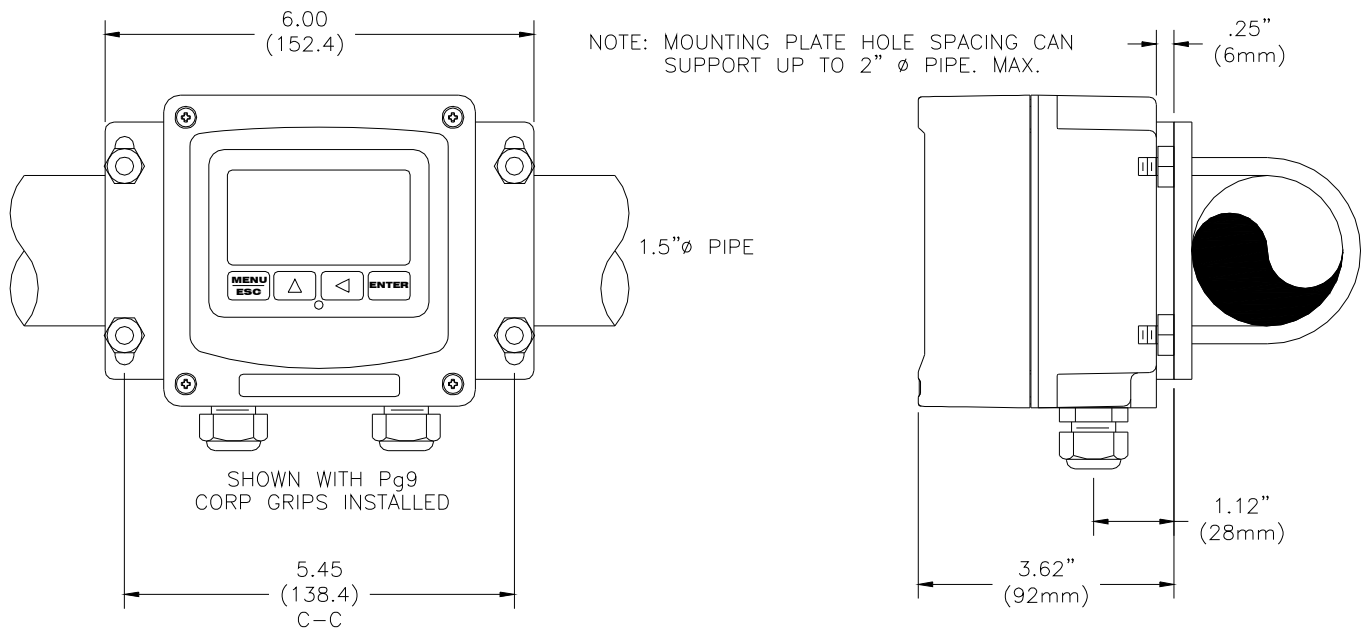

Figure 7 - Pipe Mounting Diagram

Part 3 – Sensor/Flowcell Mounting

3.1 General

Select a location within the maximum sensor cable length for mounting of the sensor flow cell.

3.2 Constant-Head Flowcell

Free chlorine sensors are best used in a constant-head overflow chamber because variations in sample flow rate and pressure can cause unstable readings. When monitoring low concentrations (below 0.5 PPM), this method should always be used.

Mechanical installation of the flow cell requires that it be mounted to a wall or other convenient flat surface. Alternatively, the mounting holes on the plate will accommodate a 2" U-bolt for mounting the plate to a 2" pipe. Figure 8 below shows the dimensions and mounting hole locations for the flow cell. Be sure to allow enough clearance on the left side of the flow cell for insertion and removal of the sensor. About 12 inches clearance is recommended.

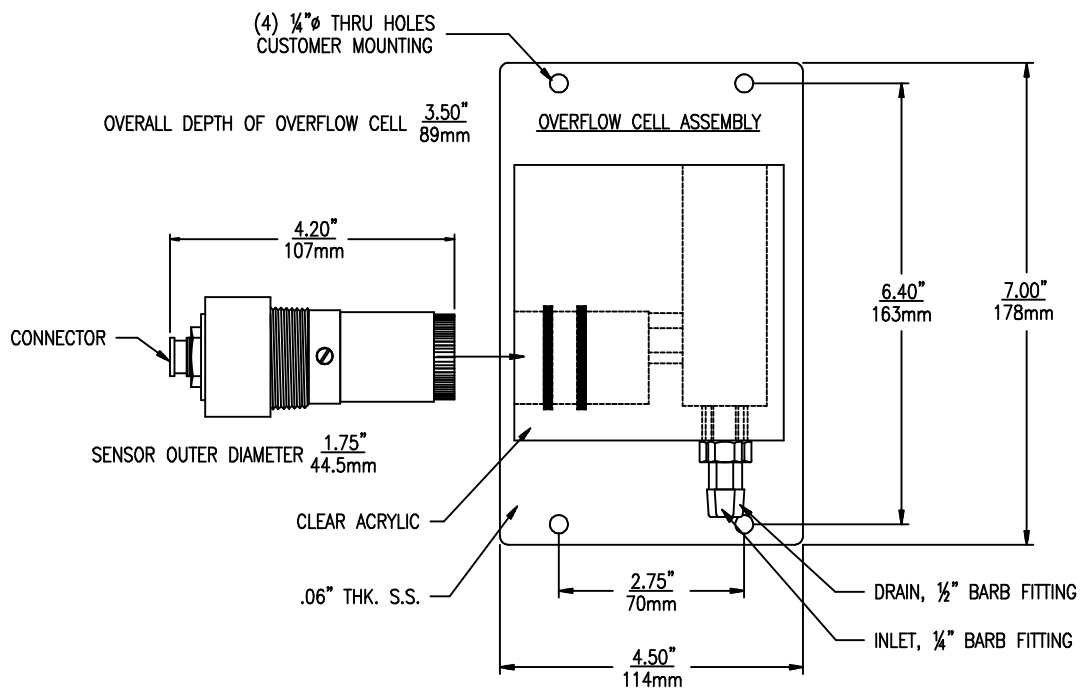

Figure 8 - Constant Head Flowcell Details

Once mounted, inlet and drain connections must be made. The flow cell contains a 1/8" MNPT inlet connection and a 3/8" MNPT drain connection. Hose barbs for the inlet and drain connections are supplied with the flow cell for use with flexible tubing. The inlet hose barb is used with 1/4" I.D. tubing and the drain hose barb is used with 1/2" I.D. tubing.

3.3 Sealed Flowcell

Applications where the sample inlet flow is well controlled can use a simpler sealed flowcell. Using this flowcell requires that flow be controlled externally to about 400 cc/min. Variable flow rate or variable pressure will cause unstable readings in this flowcell. ATI offers a special flow control element that can be used ahead of this flowcell on the incoming sample line. The flow control is part no. (55-0048). It will control the inlet flowrate at 400 cc/min. with inlet pressure variations from 5-150 PSIG. A 50 micron y-strainer ahead of the flow control element is recommended. The sealed flowcell provides a drain vent with check valve to avoid pulling a vacuum on the flow chamber.

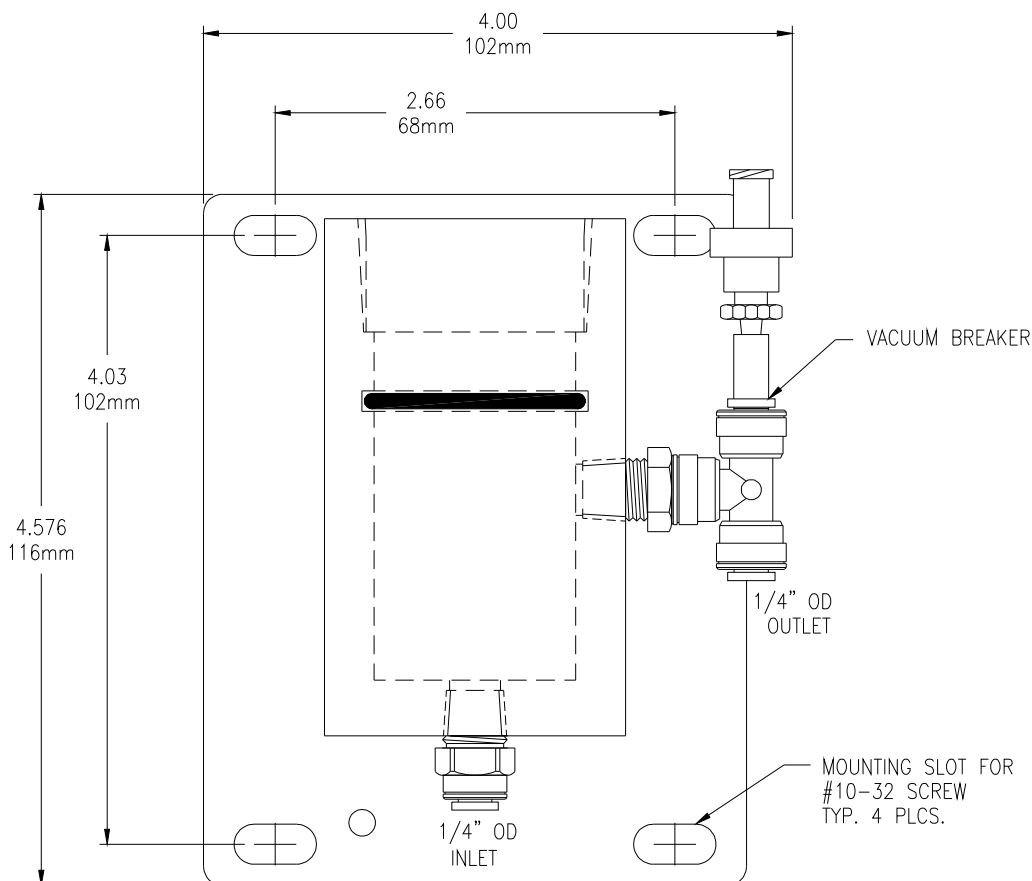

Figure 9 - Sealed Cl₂ Flowcell Details

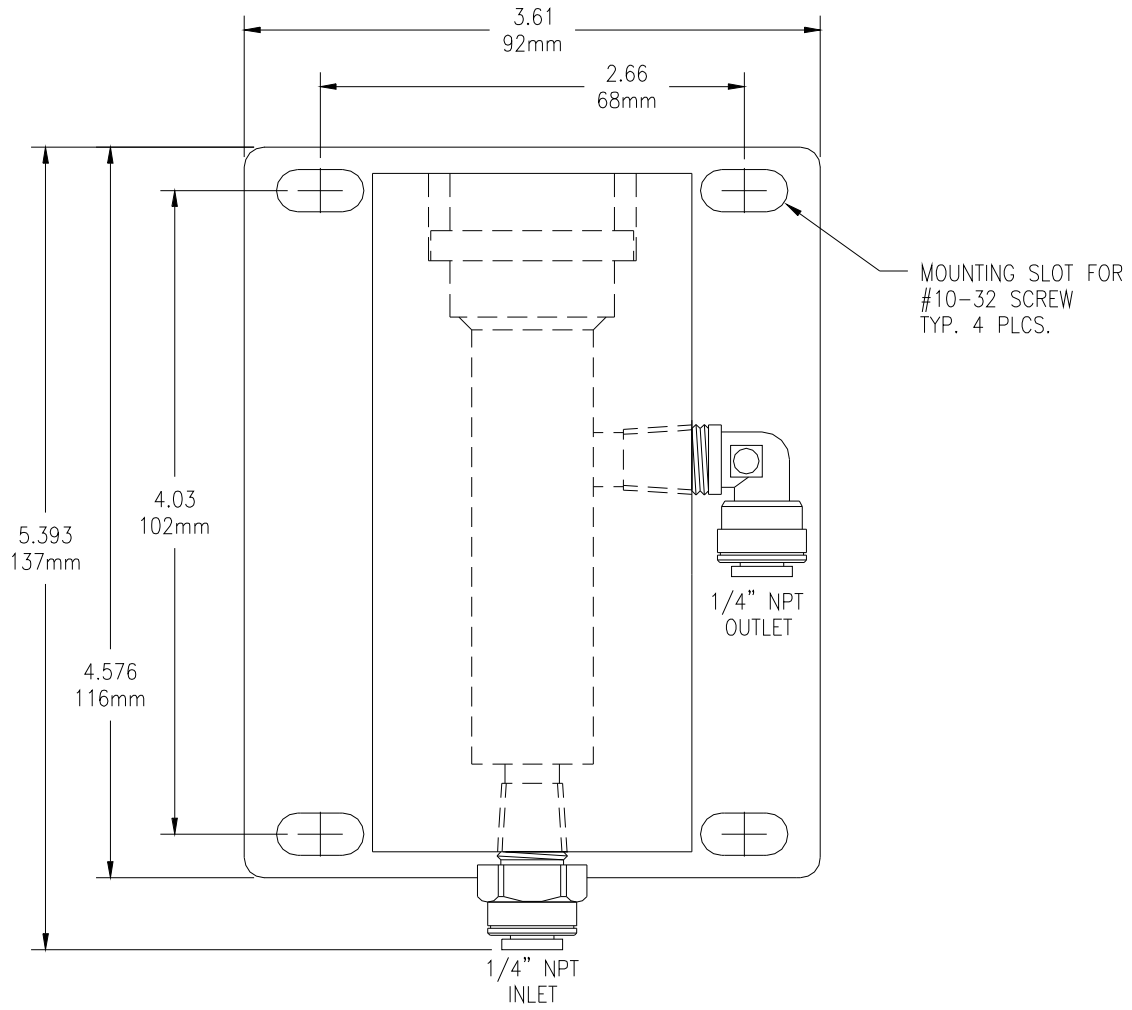

Figure 10 - Sealed pH Flowcell Details

Part 4 – Electrical Installation

4.1 General

The Q45 is powered in one of 3 ways, depending on the version purchased. The 2-wire version is a 16-35 VDC powered transmitter. The battery powered unit is supplied with 2-“C” cell batteries. The 5-17 VDC Externally Powered Transmitter is designed for low power operation for solar power applications. Please verify the type of unit before connecting any power.

WARNING: Do not connect AC line power to the 2-wire module. Severe damage will result.

Important Notes:

1. Use wiring practices that conform to all national, state and local electrical codes. For proper safety as well as stable measuring performance, it is important that the earth ground connection be made to a solid ground point from terminal 15 (Figure 11).
2. Do NOT run sensor cables or instrument 4-20 mA output wiring in the same conduit that contains AC power wiring. AC power wiring should be run in a dedicated conduit to prevent electrical noise from coupling with the instrumentation signals.
3. This analyzer must be installed by specifically trained personnel in accordance with relevant local codes and instructions contained in this operating manual. Observe the analyzer's technical specifications and input ratings.

4.2 Two-Wire

In the two-wire configuration, a separate DC power supply must be used to power the instrument. The exact connection of this power supply is dependent on the control system into which the instrument will connect. See Figure 11 for further details. Any twisted pair shielded cable can be used for connection of the instrument to the power supply. Route signal cable away from AC power lines, adjustable frequency drives, motors, or other noisy electrical lines. Do not run sensor or signal cables in conduit that contains AC power lines or motor leads.

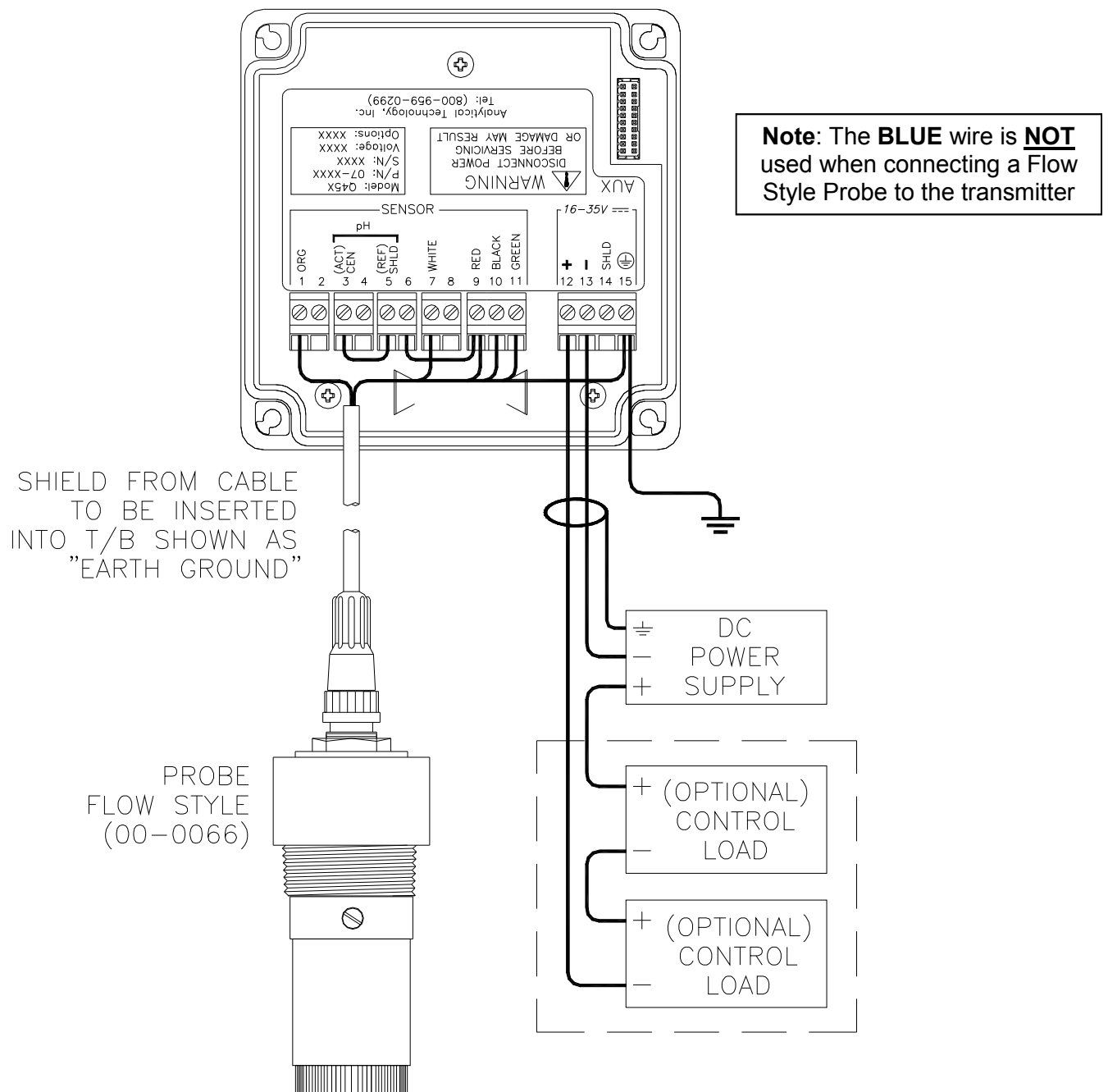

Figure 11 - Loop Power Sensor Connection

- Notes:**
1. Voltage between Terminals 12 and 13 MUST be between 16 and 35 VDC.
 2. Earth ground into Terminal 15 is HIGHLY recommended. This connection can greatly improve stability in electrically noisy environments.

4.21 Load Drive

In the two-wire configuration, the load-drive level is dependant on the DC supply voltage provided to the controller.

The two-wire instrument can operate on a power supply voltage of between 16 and 35 VDC. The available load drive capability can be calculated by applying the formula $V/I=R$, where V=load drive voltage, I=maximum loop current (in Amperes), and R=maximum resistance load (in Ohms).

To find the load drive voltage of the two-wire Q45, subtract 16 VDC from the actual power supply voltage being used (the 16 VDC represents insertion loss). For example, if a 24 VDC power supply is being used, the load drive voltage is 8 VDC.

The maximum loop current of the two-wire Q45 is always 20.00 mA, or .02 A. Therefore,

$$\frac{(\text{Power Supply Voltage} - 16)}{.02} = R_{MAX}$$

For example, if the power supply voltage is 24 VDC, first subtract 16 VDC, and then divide the remainder by .02. $8/.02 = 400$; therefore, a 400 Ohm maximum load can be inserted into the loop with a 24 VDC power supply.

Similarly, the following values can be calculated:

Power Supply Voltage (VDC)	Total Load (Ohms)
16.0	0
20.0	200
24.0	400
30.0	700
35.0	950

4.3 Sensor Wiring

The sensor cable can be quickly connected to the Q45 terminal strip by matching the wire colors on the cable to the color designations on the label in the monitor. A junction box is also available to provide a break point for long sensor cable runs. Route signal cable away from AC power lines, adjustable frequency drives, motors, or other noisy electrical signal lines. Do not run sensor or signal cables in conduit that contains AC power lines or motor leads.

4.4 Direct Sensor Connection

Sensor connections are made in accordance with Figure 11 or Figure 13. The sensor cable can be routed into the enclosure through one of cord-grips supplied with the unit. Routing sensor wiring through conduit is only recommended if a junction box is to be used. Some loose cable is needed near the installation point so that the sensor can be inserted and removed easily from the flowcell.

Cord-grips used for sealing the cable should be snugly tightened after electrical connections have been made to prevent moisture incursion. When stripping cables, leave adequate length for connections in the transmitter enclosure as shown below. The standard 25 ft. sensor cable normally supplied with the system is already stripped and ready for wiring. This cable can be cut to a shorter length if desired to remove extra cable in a given installation. Do not cut the cable so short as to make installation and removal of the sensor difficult.

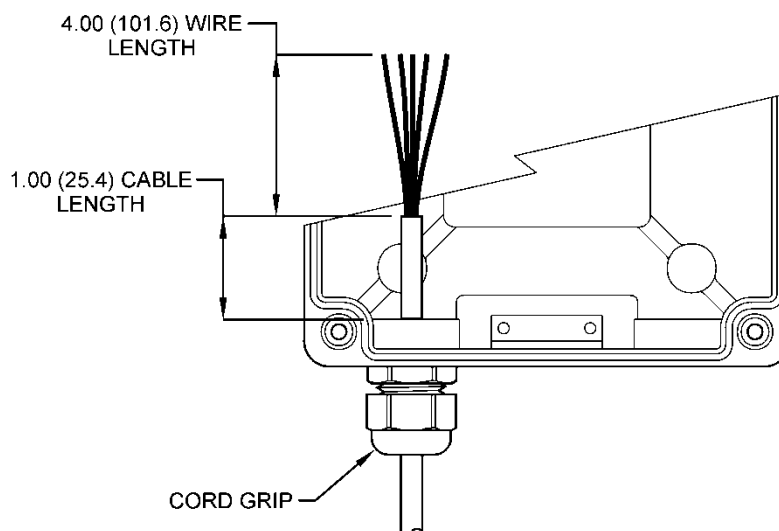

Figure 12 - Sensor Cable Preparation

4.5 Junction Box Connection

Installations where the sensor is to be located more than 25 feet from the monitor (max. 100 feet) require the use of a junction box. The junction box is shown in Figure 13 and is supplied with two cable glands on the bottom of the enclosure.

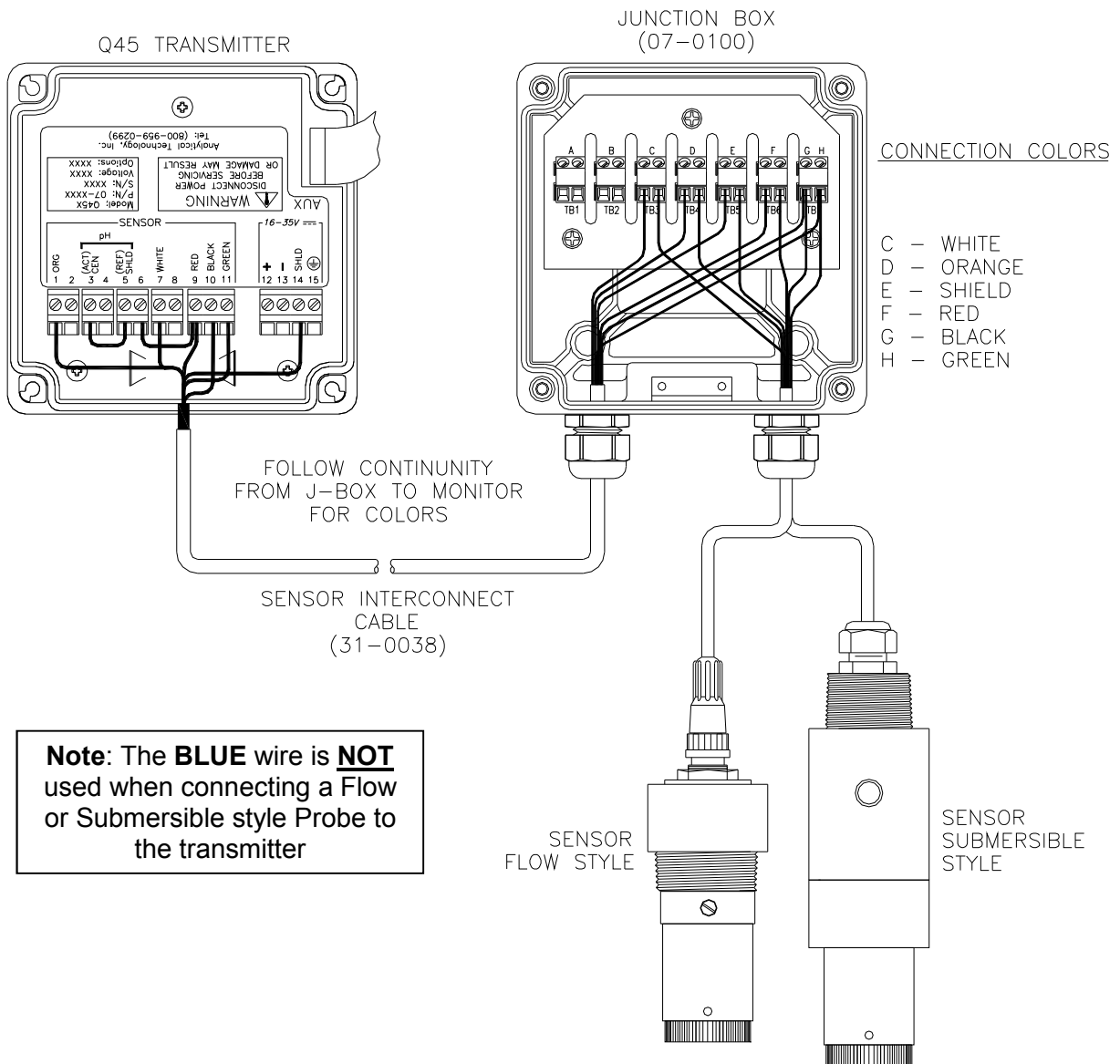

Figure 13 - Junction Box Interconnect Wiring

4.7 Optional pH Compensation Input

The Q45H may be configured for pH compensation to maintain excellent accuracy in applications where the pH can vary. To utilize the feature, a pH sensor must be connected to terminals 3 and 5 as shown in Figure 14. Note that jumpers are installed at the factory between terminals 3 and 5, and terminals 6 and 9. When no pH sensor input is connected, these jumpers reduce the potential for noise pickup in the circuit. **Remove the jumpers if a pH sensor is added.**

Two types of pH sensors are available for connection to the Q45H/62 monitor. A battery powered sensor with internal preamp, #07-0096, provides an amplified signal of 0.3 – 1.5 VDC. A standard pH sensor without preamp, #63-0101, is also available, but the maximum cable length for this sensor is 25 ft. (7.5 m.) When this sensor is used with the constant-head flowcell, an adapter is supplied to allow the sensor to sit in the inlet chamber.

The pH correction can also be done using the analog output of another pH transmitter. When using the output from a separate pH transmitter, signal isolation is critical and an isolator may be required for proper operation.

If pH compensation is to be used, the pH input feature must be enabled and the correct pH sensor type must be selected in the Configuration Menu. If an 63-0101 sensor is used, select Sensor Type #1. If you are using an 07-0096 sensor (Q22P) or an external pH Transmitter input, select Sensor Type #2. See diagram on the next page for sensor hook-up information.

Note that a junction box may not be used with a 63-0101 pH sensor.

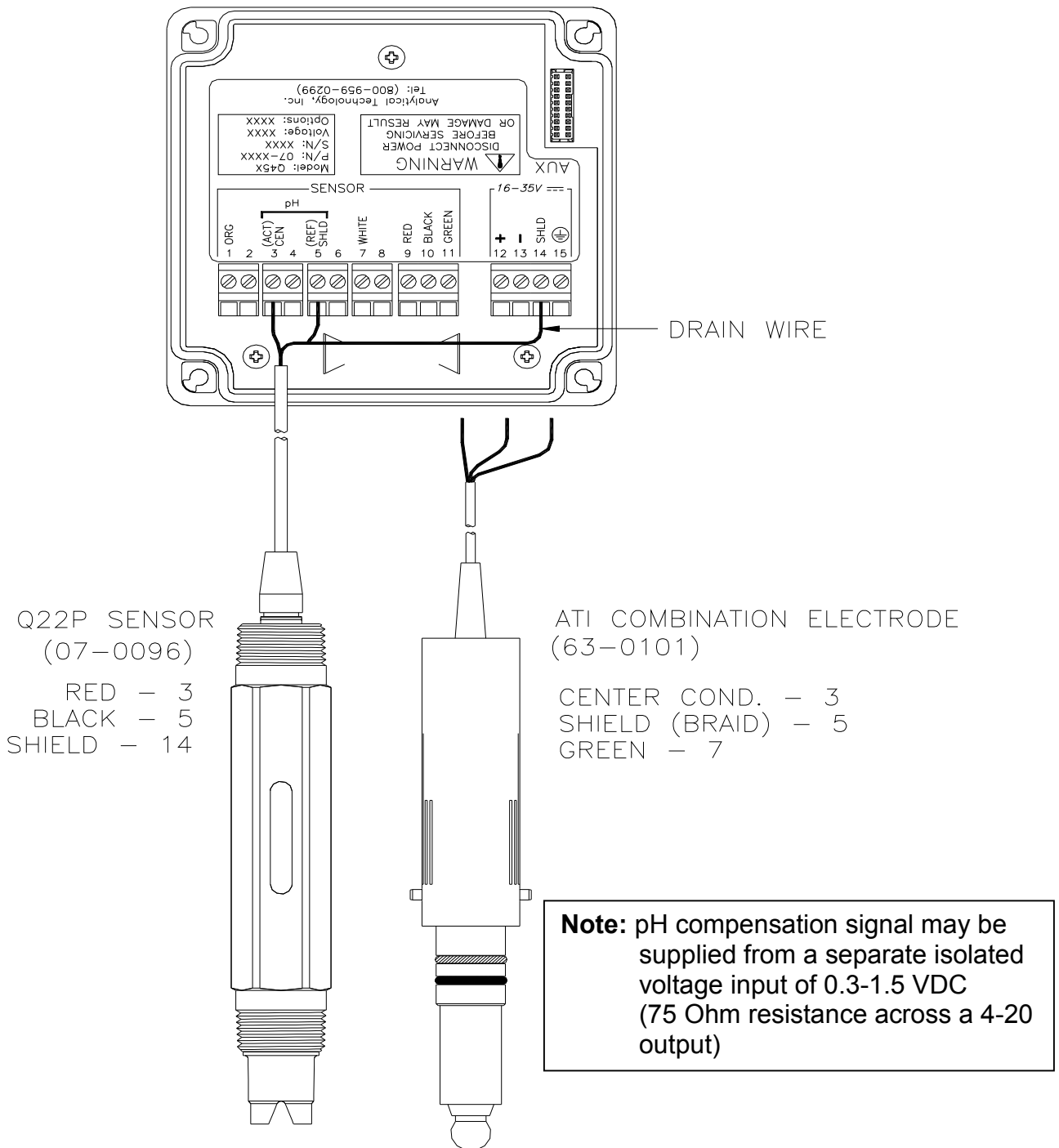

Figure 14 - Optional pH Compensator Connection

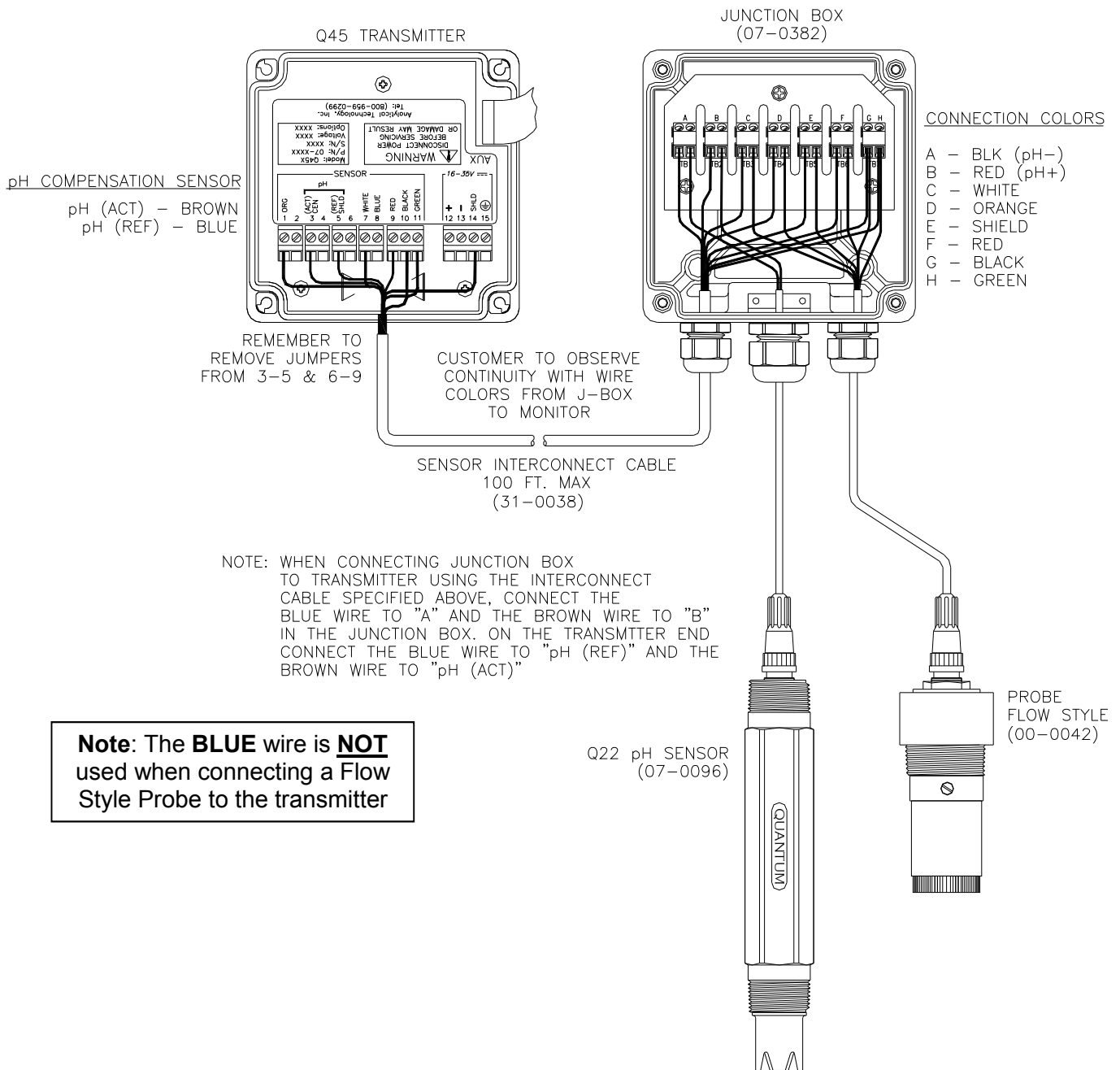

Figure 15 - Optional pH Compensator Connection w/Junction Box

Part 5 – Sensor Assembly

5.1 Chlorine Sensor Preparation

The chlorine sensor supplied with the Q45H is shipped dry. It will not operate until it is prepared by adding electrolyte and a membrane. Preparation of the sensor for operation must be done carefully. The procedure should be done by a qualified technician, and it should only be done when the system is ready for operation. Until then, it is best to leave the sensor in the condition in which it is received.

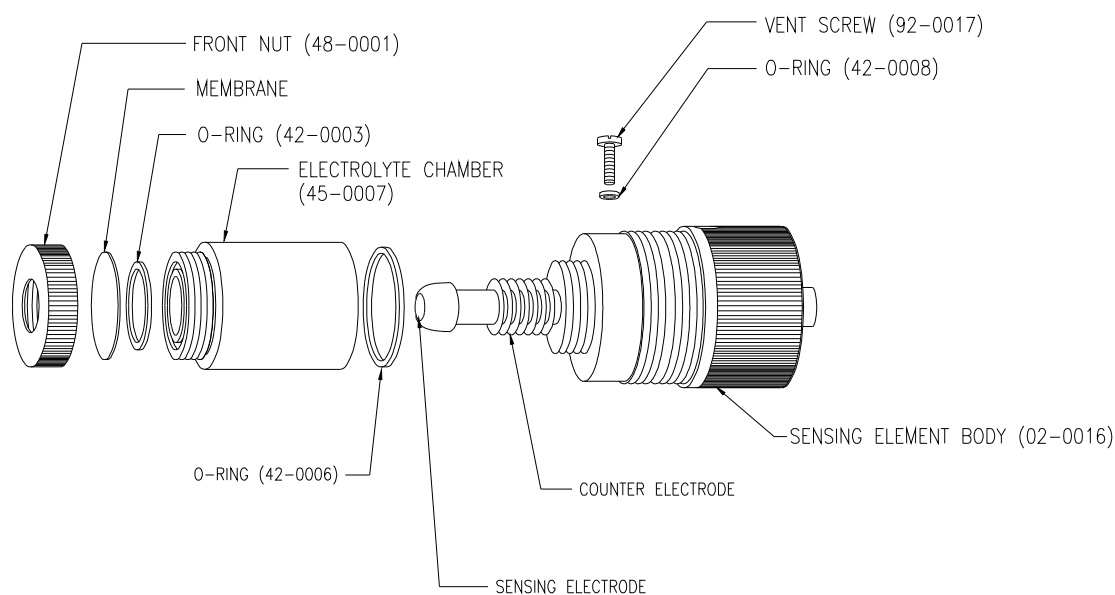

Figure 16 - Chlorine Sensor Assembly

Follow the procedure below to prepare the chlorine sensor for operation:

1. Unscrew the electrolyte chamber from the assembled sensor and also remove the vent screw from the side of the sensor body.
2. Remove the front nut from the bottom of the chamber and discard the protective membrane. O-rings are contained in grooves on both the bottom and top of the chamber. Be sure that these o-rings remain in place.
3. From the package of membranes supplied with the sensor, place a new membrane into the front nut. **The membrane is white in color and is separated from other membranes by a light blue paper spacer.**

4. Screw the front nut on to the chamber until you feel the o-ring compress. Hand tight compression is all that is needed. Do not use tools to tighten. The membrane should be flat across the bottom of the chamber without wrinkles.
5. Fill the chamber with electrolyte until the level reaches the bottom of the internal threads.
6. Slowly screw the chamber onto the sensor body. A small amount of electrolyte will run out of the hole from which the vent screw was removed. Place a paper towel around the sensor to absorb the electrolyte overflow. The electrolyte is harmless and will not irritate skin. Tighten the chamber until the o-ring at the top of the chamber is compressed. Once again, do not use tools to tighten.
7. Shake excess electrolyte from the fill hole on the side of the sensor and replace the vent screw.

The sensor is now ready for operation. The membrane should be stretched tightly across the tip of the sensor.

CAUTION: When handling the assembled sensor, do not set the sensor on its tip or damage to the membrane will result. Severe impacts on the tip of the sensor from dropping or other misuse may cause permanent damage to the sensor.

5.2 Optional pH Sensors

As mentioned previously, two optional pH sensors are available for use with the Q45H system, one battery powered and one without an internal preamp. The pH sensors may be used to simply provide for continuous monitoring of both free chlorine and pH, or they can be used to correct the free chlorine sensor reading for changes due to pH changes in the sample. Both sensors are shipped with a protective rubber boot containing a small amount of salt solution to keep the glass elements in good condition and ready for use.

No special preparations are required for use of these electrodes. The protective boot should remain in place until the system is ready for operation. **Do not remove the protective boot and allow the sensor to sit in the air for an extended period of time. The pH electrodes MUST remain wet.**

When ready for operation, simply remove the rubber boot from the end of the sensor and place the sensor into the inlet chamber of the chlorine overflow cell. It is placed directly above the sample inlet tube. You will need to slide the flowcell chamber cover out of the way to put the pH sensor in place.

Part 6 – Configuration

6.1 User Interface

The user interface for the Q45 Series instrument consists of a custom display and a membrane keypad. All functions are accessed from this user interface (no internal jumpers, pots, etc.).

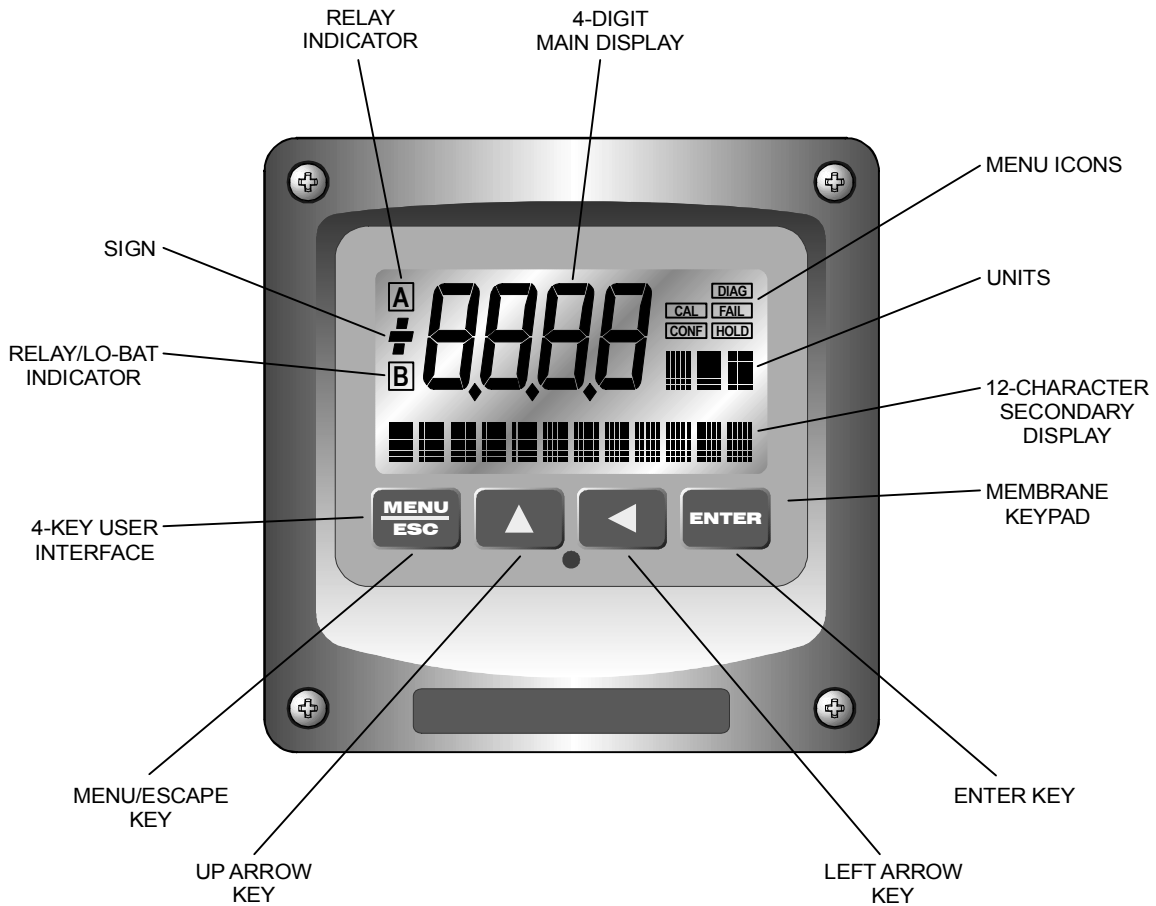

Figure 17 - User Interface

6.11 Keys

All user configurations occur through the use of four membrane keys. These keys are used as follows:

- | | |
|---------------------|---|
| MENU/ESC | To scroll through the menu section headers or to escape from anywhere in software. The escape sequence allows the user to back out of any changes in a logical manner. Using the escape key aborts all changes to the current screen and backs the user out one level in the software tree. The manual will refer to this key as either MENU or ESC, depending upon its particular function. In the battery-powered version of the Q45, this is also the ON button. |
| UP (arrow) | To scroll through individual list or display items and to change number values. |
| LEFT (arrow) | To move the cursor from right to left during changes to a number value. |
| ENTER | To select a menu section or list item for change and to store any change. |

6.12 Display

The large custom display provides clear information for general measurement use and user configuration. There are three main areas of the display: the main parameter display, the secondary message line, and the icon area.

- | | |
|-----------------------|--|
| Main Parameter | During normal operation, the main parameter display indicates the present process input with sign and units. This main display may be configured to display any of the main measurements that the system provides. During configuration, this area displays other useful set-up information to the user. |
|-----------------------|--|

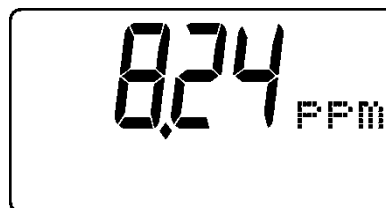

Lower Line

During normal operation, the lower line of the display indicates user-selected secondary measurements that the system is making. This also includes calibration data from the last calibration sequence and the transmitter model number and software version. During configuration, the lower line displays menu items and set-up prompts to the user. Finally, the lower line will display error messages when necessary. For a description of all display messages, refer to Section 10.4 Display Messages.

**Icon Area**

The icon area contains display icons that assist the user in set-up and indicate important states of system functions. The CAL, CONFIG, and DIAG icons are used to tell the user what branch of the software tree the user is in while scrolling through the menu items. This improves software map navigation dramatically. Upon entry into a menu, the title is displayed (such as CAL), and then the title disappears to make way for the actual menu item. However, the icon stays on.

HOLD

The HOLD icon indicates that the current output of the transmitter has been put into output hold. In this case, the output is locked to the last input value measured when the HOLD function was entered. HOLD values are retained even if the unit power is cycled.

FAIL

The FAIL icon indicates that the system diagnostic function has detected a problem that requires immediate attention. This icon is automatically cleared once the problem has been resolved.

6.2 Software

The software of the Q45H is organized in an easy to follow menu-based system. All user settings are organized under five menu sections: Measure, Calibration [CAL], Configuration [CONFIG], Control [CONTROL] and Diagnostics [DIAG].

Note: The default Measure Menu is display-only and has no menu icon.

6.21 Software Navigation

Within the CAL, CONFIG, CONTROL, and DIAG menu sections is a list of selectable items. Once a menu section (such as CONFIG) has been selected with the MENU key, the user can access the item list in this section by pressing either the ENTER key or the UP arrow key. The list items can then be scrolled through using the UP arrow key. Once the last item is reached, the list wraps around and the first list item is shown again. The items in the menu sections are organized such that more frequently used functions are first, while more permanent function settings are later in the list. See Figure 18 for a visual description of the software.

Each list item allows a change to a stored system variable. List items are designed in one of two forms: simple single variable, or multiple variable sequences. In the single variable format, the user can quickly modify one parameter - for example, changing temperature display units from °F to °C. In the multiple variable sequence, variables are changed as the result of some process. For example, the calibration of chlorine generally requires more than one piece of information to be entered. The majority of the menu items in the software consist of the single variable format type.

Any data that may be changed will be flashing. This flashing indicates user entry mode and is initiated by pressing the ENTER key. The UP arrow key will increase a flashing digit from 0 to 9. The LEFT arrow key moves the flashing digit from right to left. Once the change has been completed, pressing ENTER again stores the variable and stops the flashing. Pressing ESC aborts the change and also exits user entry mode.

The starting (default) screen is always the Measure Menu. The UP arrow key is used to select the desired display. From anywhere in this section the user can press the MENU key to select one of the four Menu Sections.

The UP arrow icon next to all list items on the display is a reminder to scroll through the list using the UP arrow key.

To select a list item for modification, first select the proper menu with the MENU key. Scroll to the list item with the UP arrow key and then press the ENTER key. This tells the system that the user wishes to perform a change on that item. For single item type screens, once the user presses the ENTER key, part or all of the variable will begin to flash, indicating that the user may modify that variable using the arrow keys. However, if the instrument is locked, the transmitter will display the message **Locked!** and will not enter user entry mode. The instrument must be unlocked by entering the proper code value to allow authorized changes to user entered values. Once the variable has been reset, pressing the ENTER key again causes the change to be stored and the flashing to stop. The message **Accepted!** will be displayed if the change is within pre-defined variable limits. If the user decides not to modify the value after it has already been partially changed, pressing the ESC key aborts the modification and returns the entry to its original stored value.

In a menu item which is a multiple variable sequence type, once the ENTER key is pressed there may be several prompts and sequences that are run to complete the modification. The ESC key can always be used to abort the sequence without changing any stored variables.

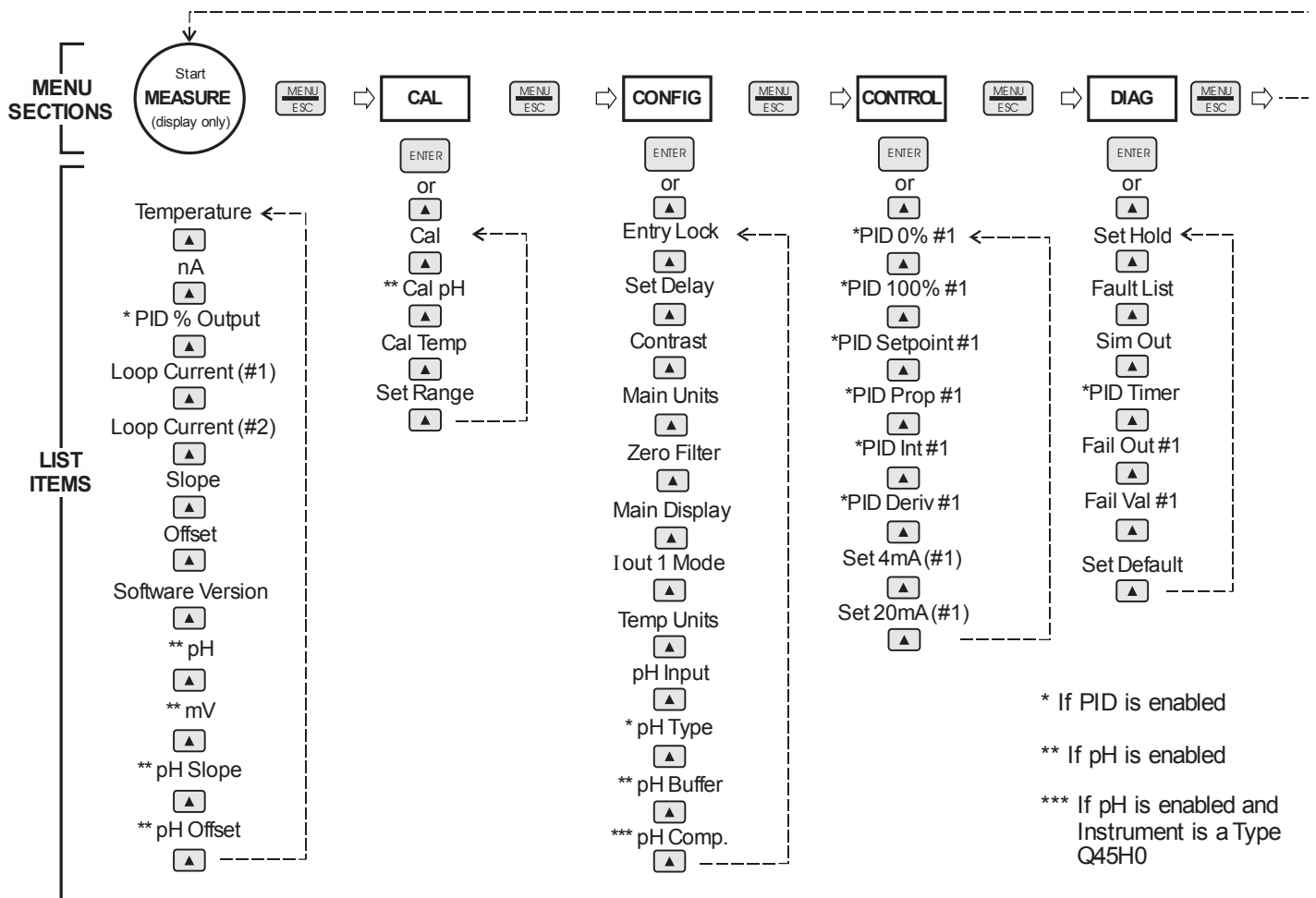

Figure 18 - Software Map

6.22 Measure Menu [MEASURE]

The default menu for the system is the display-only menu MEASURE. This menu is a display-only measurement menu, and has no changeable list items. When left alone, the instrument will automatically return to this menu after approximately 30 minutes. While in the default menu, the UP arrow allows the user to scroll through the secondary variables on the lower line of the display. A brief description of the fields in the basic transmitter version is as follows:

TRANSMITTER MEAS SCREENS:

25.7°C	Temperature display. Can be displayed in °C or °F, depending on user selection. A small “m” on the left side of the screen indicates the transmitter has automatically jumped to a manual 25°C setting due to a failure with the temperature signal input.
32.0 nA	Raw sensor current. Useful for diagnosing problems.
100% 20.00 mA	PID Status screen (if enabled.) Shows the present controller output level on left, and actual transmitter current on the right. The controller can be placed in manual while viewing this screen by pressing and holding the ENTER key for 5 seconds until a small flashing “m” appears on the screen. At that point the controller output can be adjusted up or down using the UP and LEFT arrow keys. To return to automatic operation, press and hold the ENTER key for 5 seconds and the “M” will disappear.
20.00 mA	Transmitter output current.
Slope = 100%	Sensor output response vs. ideal calibration. This value updates after each calibration. As the sensor ages, the slope reading will decay indicating sensor aging. Useful for resolving sensor problems.
Offset = 0.0 nA	Sensor output current at a zero ppm input. This value updates after a zero-calibration has been performed. Useful for resolving sensor problems.
Q45H0 v 4.02	Transmitter software version number.

7.56 pH	Measured pH value on AUX input (if enabled.)
5.00 mV	pH sensor mV output (if enabled)
Slope = 100%	pH sensor slope response vs. ideal calibration. This value will update after each calibration. As the pH sensor ages, the slope reading will decay. This is useful for solving sensor problems (if enabled).
Offset = X.X mV	pH sensor current output at 7 pH input. This value updates after calibration is performed and is useful for resolving sensor problems.

Note: A display test (all segments ON) can be actuated by pressing and holding the ENTER key while viewing the model/version number on the lower line of the display.

The MEASURE screens are intended to be used as a very quick means of looking up critical values during operation or troubleshooting.

6.23 Calibration Menu [CAL]

The calibration menu contains items for frequent calibration of user parameters. There are four items in this list: Cal Chlor, Cal pH (if enabled), Cal Temp and Set Range.

Cal Cl₂	The chlorine calibration function allows the user to adjust the transmitter span reading to match a reference solution, or to set the sensor zero point. See Part 7 – Calibration for more details.
Cal pH	The pH calibration function allows the user to (if enabled) adjust the transmitter offset and span to match the sample or reference buffers. See Part 7 – Calibration for more details.
Cal Temp	The temperature calibration function allows the user to adjust the offset of the temperature response by a small factor of ± 5 °C. The temperature input is factory calibrated to very high accuracy. However, long cable lengths and junction boxes may degrade the accuracy of the temperature measurement in some extreme situations. Therefore, this feature is

provided as an adjustment. See Part 7 – Calibration for more details.

Set Range

This function allows the user to set the display range of the transmitter to a specific application. Once set, all output functions use this display range to establish configuration settings. Press ENTER to initiate user entry mode, and the value will flash. Use the arrow keys to modify value; available ranges include 200.0 ppb, 2.000 ppm, 20.00 ppm, and 200.0 ppm. Press ENTER to store the new value. The display range does not affect the internal auto ranging scaler that, therefore, sensitivity is to specification in any user selected range.

6.24 Configuration Menu [CONFIG]

The Configuration Menu contains all of the general user settings:

Entry Lock

This function allows the user to lock out unauthorized tampering with instrument settings. All settings may be viewed while the instrument is locked, but they cannot be modified. The Entry Lock feature is a toggle-type setting; that is, entering the correct code will lock the transmitter and entering the correct code again will unlock it. The code is preset at a fixed value. Press ENTER to initiate user entry mode and the first digit will flash. Use arrow keys to modify value. **See end of manual for the Q45H lock/unlock code.** Press ENTER to toggle lock setting once code is correct. Incorrect codes do not change state of lock condition.

Set Delay

The delay function sets the amount of damping on the instrument. This function allows the user to apply a first order time delay function to the chlorine measurements being made. Both the display and the output value are affected by the degree of damping. Functions such as calibration are not affected by this parameter. The calibration routines contain their own filtering and stability monitoring functions to minimize the calibration timing. Press ENTER to initiate user entry mode, and the value will flash. Use the arrow keys to modify value; range is 0.1 to 9.9 minutes. Press ENTER to store the new value.

- Contrast** This function sets the contrast level for the display. The custom display is designed with a wide temperature range, Super-Twist Nematic (STN) fluid.
- The STN display provides the highest possible contrast and widest viewing angle under all conditions. Contrast control of this type of display is generally not necessary, so contrast control is provided as a means for possible adjustment due to aging at extreme ranges. In addition, the display has an automatic temperature compensation network. Press ENTER to initiate user entry mode, and the value will flash. Use arrow keys to modify the value; range is 0 to 8 (0 being lightest). Press ENTER to update and store the new value.
- Main Units** This function allows the user to select either PPM or mg/l for the chlorine measurement.
- Zero Filter** This function forces the reading to zero when reading is below the entered value. For example, If the entered value were 0.0020 the display at 0.0019 would then indicate 0.0000. This feature is useful in blanking out zero noise.
- Main Display** This function allows the user to change the measurement in the primary display area. The user may select between chlorine, sensor temperature, or output current. Using this function, the user may choose to put temperature in the main display area and chlorine on the secondary, lower line of the display. Press ENTER to initiate user entry mode, and the entire value will flash. Use the UP arrow key to modify the desired display value. Press ENTER to store the new value.
- Out1 Mode** This function sets analog output #1 to either track chlorine (default) or enables the PID controller to operate on the chlorine input. Press ENTER to initiate user entry mode, and the entire value will flash. Use the UP arrow key to modify the desired value; selections include 1-ppm for chlorine tracking or 2-PID for chlorine PID control. Press ENTER to store the new value.
- Temp Units** This function sets the display units for temperature measurement. Press ENTER to initiate user entry mode, and the entire value will flash. Use the UP arrow key to modify the desired display value. The choices are °F and °C. Press ENTER to store the new value.

pH Input Enables the auxiliary pH input on the instrument. Once enabled, an optional pH sensor can be added to the instrument to provide for additional monitoring of pH (dual instrument, chlorine + pH output.)

For the relay-based analyzer with two analog outputs, the pH signal can also be sent to one of the analog outputs for monitoring of pH. Once enabled, the pH input value is displayed on the lower line of the MEASURE screens. Press ENTER to initiate user entry mode, and the entire value will flash. Use the UP arrow key to modify the desired display value. The choices are **OFF** and **ON**. Press ENTER to store the new value.

pH Type Allows the user to select either 1-Comb or 2-Q22P. The 1-Comb selection configures the monitor for a standard pH electrode without using its temperature compensation but in turn, uses the temperature compensator from the chlorine sensor. The 2-Q22P selection configures the monitor for use with the Q22P sensor or for the 4-20 mA input from any other pH monitor.

pH Buffer This is a multiple variable function that allows the user to choose which pH buffer sets that will be utilized in the 2-point calibration mode. The Q45H contains 3 sets of built-in buffer tables with compensation values ranging from 0 to 95 °C. During 2-point calibration, the instrument will automatically identify which buffer is being used and compensate for the value based on the built-in tables. This allows very quick, highly accurate calibrations by the user. The order in which the buffers are used during calibration is unimportant, since the system automatically chooses the correct buffer.

The default setting for this feature is OFF, which disables the auto-recognition function. Press ENTER to change this setting. The buffer table set options are: 1: [4/7/10], 2: [4/7/9.18], and 3: [4.65/6.79/9.23]. See Figure 19 for buffer tables. Once the buffer set is selected, press ENTER and the message Accepted! will be displayed on the lower line.

Table 1

4.00 pH		7.00 pH		10.00 pH	
°C	pH	°C	pH	°C	pH
0	4.00	0	7.10	0	10.27
10	3.99	10	7.06	10	10.15
20	4.00	20	7.02	20	10.05
30	4.01	30	6.99	30	9.95
40	4.03	40	6.97	40	9.87
50	4.05	50	6.98	50	9.80
60	4.08	60	6.98	60	9.75
70	4.12	70	6.97	70	9.73
80	4.16	80	6.99	80	9.73
90	4.21	90	7.01	90	9.75
95	4.24	95	7.01	95	9.77

Table 2

4.00 pH		7.00 pH		9.18 pH	
°C	pH	°C	pH	°C	pH
0	4.00	0	7.10	0	9.46
10	3.99	10	7.06	10	9.33
20	4.00	20	7.02	20	9.23
30	4.01	30	6.99	30	9.14
40	4.03	40	6.97	40	9.07
50	4.05	50	6.98	50	9.01
60	4.08	60	6.98	60	8.96
70	4.12	70	6.97	70	8.92
80	4.16	80	6.99	80	8.89
90	4.21	90	7.01	90	8.85
95	4.24	95	7.01	95	8.83

Table 3

4.65 pH		6.79 pH		9.23 pH	
C	pH	°C	pH	°C	pH
0	4.67	0	6.89	0	9.48
10	4.66	10	6.84	10	9.37
20	4.65	20	6.80	20	9.27
30	4.65	30	6.78	30	9.18
40	4.66	40	6.76	40	9.09
50	4.68	50	6.76	50	9.00
60	4.70	60	6.76	60	8.92
70	4.72	70	6.76	70	8.88
80	4.75	80	6.78	80	8.85
90	4.79	90	6.80	90	8.82
95	4.79	95	6.80	95	8.82

Figure 19 - Automatic pH Buffer Tables

pH Comp Enables pH compensation of free chlorine measurements using a built in comp table. An optional pH sensor is required for this compensation method, and “pH Input” menu item above must be selected to be ON. pH type must also be selected. Once enabled, this feature will compensate for reduced chlorine readings that would normally result at elevated pH readings. A built-in compensation table increases the chlorine reading gradually as pH increases – in an effort to maintain a constant chlorine measurement. Press ENTER to initiate user entry mode, and the entire value will flash. Use the UP arrow key to modify the desired display value. The choices are **OFF** and **ON**. Press ENTER to store the new value. See Part 7 – Calibration for more details.

6.25 Control Menu [CONTROL]

The Control Menu contains all of the output control user settings:

Set PID 0%
Set PID 100%
[out1=PID]

If the PID is enabled, this function sets the minimum and maximum controller end points. Unlike the standard 4-20 mA output, the controller does not “scale” output values across the endpoints. Rather, the endpoints determine where the controller would normally force minimum or maximum output in an attempt to recover the setpoint (even though the controller can achieve 0% or 100% anywhere within the range.)

If the 0% point is lower than the 100% point, then the controller action will be “reverse” acting. That is, the output of the controller will increase if the measured value is less than the setpoint, and the output will decrease if the measured value is larger than the setpoint. Flipping the stored values in these points will reverse the action of the controller to “direct” mode.

The entry value is limited to a value within the range specified in “Set Range”, and the 0% and the 100% point must be separated by at least 1% of this range Use the LEFT arrow key to select the first digit to be modified. Then use the UP and LEFT arrow keys to select the desired numerical value. Press ENTER to store the new value.

PID Setpnt [lout1=PID]	The measured value which the controller is attempting to maintain by adjusting output value. It is the nature of the PID controller that it never actually gets to the exact value and stops. The controller is continually making smaller and smaller adjustments as the measured value gets near the setpoint.
PID Prop [lout1=PID]	Proportional gain factor. The proportional gain value is a multiplier on the controller error (difference between measured value and setpoint value.) Increasing this value will make the controller more responsive.
PID Int [lout1=PID]	Integral is the number of “repeats-per-minute” of the action of the controller. It is the number of times per minute that the controller acts on the input error. At a setting of 2.0 rpm, there are two repeats every minute. If the integral is set to zero, a fixed offset value is added to the controller (manual reset.) Increasing this value will make the controller more responsive.
PID Deriv [lout1=PID]	Derivative is a second order implementation of Integral, used to suppress “second-order” effects from process variables. These variables may include items like pumps or mixers that may have minor impacts on the measured value. The derivative factor is rarely used in water treatment process, and therefore, it is best in most cases to leave it at the default value. Increasing this value will make the controller more responsive.
Set 4 mA Set 20 mA [lout1=chlorine]	<p>These functions set the main 4 and 20 mA current loop output points for the transmitter. The units displayed depend on the selection made in the CONFIG menu for lout #1 Mode. Also, when the Relay Option Board is installed, the units will also display #1 or #2 – since there are actually two analog outputs present in this version.</p> <p>The value stored for the 4 mA point may be higher or lower than the value stored for the 20 mA point. The entry values are limited to values within the range specified in “Set Range”, and the 4 mA and the 20 mA point must be separated by at least 1% of this range Use the LEFT arrow key to select the first digit to be modified. Then use the UP and LEFT arrow keys to select the desired numerical value. Press ENTER to store the new value.</p>

6.26 Diagnostics Menu [DIAG]

The diagnostics menu contains all of the user settings that are specific to the system diagnostic functions, as well as functions that aid in troubleshooting application problems.

Set Hold

The Set Hold function locks the current loop output values on the present process value, and halts operation of the PID controller. This function can be used prior to calibration, or when removing the sensor from the process, to hold the output in a known state. Once HOLD is released, the outputs return to their normal state of following the process input. The transfer out of HOLD is bumpless on the both analog outputs - that is, the transfer occurs in a smooth manner rather than as an abrupt change. An icon on the display indicates the HOLD state, and the HOLD state is retained even if power is cycled. Press ENTER to initiate user entry mode, and entire value will flash. Use the UP arrow key to modify the desired value, selections are **ON** for engaging the HOLD function, and **OFF** to disengage the function. Press ENTER to store the new value.

Note: When the Relay Option Board is installed, the Set Hold function holds BOTH current levels, as well as ALL relay settings.

The Set Hold function can also hold at an output value specified by the user. To customize the hold value, first turn the HOLD function on. Press the ESC key to go to the DIAG Menu and scroll to Sim Output using the UP arrow key. Press ENTER. Follow the instructions under Sim Output (see following page).

CAUTION: There is no time-out on the hold feature. Once placed into hold mode, return to normal operation must be done manually.

Fault List

The Fault List screen is a read-only screen that allows the user to display the cause of the highest priority failure. The screen indicates the number of faults present in the system and a message detailing the highest priority fault present. Note that some faults can result in multiple displayed failures due to the high number of internal tests occurring. As faults are corrected, they are immediately cleared.

Faults are not stored; therefore, they are immediately removed if power is cycled. If the problem causing the faults still exists, faults will be displayed again after power is re-applied and a period of time elapses during which the diagnostic system re-detects them. The exception to this rule is the calibration failure. When a calibration fails, no corrupt data is stored. Therefore, the system continues to function normally on the data that was present before the calibration was attempted.

After 30 minutes or if power to the transmitter is cycled, the failure for calibration will be cleared until calibration is attempted again. If the problem still exists, the calibration failure will re-occur. Press ENTER to initiate view of the highest priority failure. The display will automatically return to normal after a few seconds.

PID Timer

This function sets a timer to monitor the amount of time the PID controller remains at 0% or 100%. This function only appears if the PID controller is enabled. If the timer is set to 0000, the feature is effectively disabled. If the timer value is set to any number other zero, a FAIL condition will occur if the PID controller remains at 0% or 100% for the timer value. If one of the relays is set to FAIL mode, this failure condition can be signaled by a changing relay contact.

Press ENTER to initiate user entry mode, and the entire value will flash. Use the UP arrow key to modify desired value; range of value is 0-9999 seconds. Press ENTER to store the new value.

Sim Out

The Sim Out function allows the user to simulate the chlorine level of the instrument in the user selected display range. The user enters a ppm value directly onto the screen, and the output responds as if it were actually receiving the signal from the sensor. This allows the user to check the function of attached monitoring equipment during set-up or troubleshooting. Escaping this screen returns the unit to normal operation. Press ENTER to initiate the user entry mode, and the right-most digit of the value will flash. Use arrow keys to modify desired value.

The starting display value in SIM mode will be the last read value of the input. The output will be under control of the SIM screen until the ESC key is pressed. The instrument will automatically terminate the simulated output after 30 minutes and return to normal operation unless the “HOLD” function is engaged.

Note: If the HOLD function is engaged before the Sim Output function is engaged, the simulated output will remain the same even when the ESC key is pressed. Disengage the HOLD function to return to normal output.

Fail Out

This function enables the user to define a specified value that the main current output will go to under fault conditions. When the Relay Option Board is installed, the display will read **Fail Out #1**. When enabled to **ON**, the output may be forced to the current value set in **Fail Val** (next item.) With the Fail Out setting of ON, and a Fail Val setting of 6.5 mA, any alarm condition will cause the current loop output to drop outside the normal operating range to exactly 6.5 mA, indicating a system failure that requires attention.

Press ENTER to initiate user entry mode, and the entire value will flash. Use the UP arrow key to modify desired value; selections are **ON**, **OFF**. Press ENTER to store the new value.

Fail Val

Sets the output failure value for lout#1. When **Fail Out** above is set to **ON**, this function sets value of the current loop under a FAIL condition. When the Relay Option Board is installed, the display will read **Fail Out #1**. The output may be forced to any current value between 4-20 mA.

Press ENTER to initiate user entry mode, and the entire value will flash. Use the UP arrow key to modify desired value; selections are between **4mA**, and **20mA**. Press ENTER to store the new value.

Set Default

The Set Default function allows the user to return the instrument back to factory default data for all user settings or for just the calibration default. It is intended to be used as a last resort troubleshooting procedure. All user settings or the calibration settings are returned to the original factory values. Hidden factory calibration data remains unchanged. Press ENTER to initiate user entry mode and select either All or CAL with the UP arrow key.

Part 7 – Calibration

7.1 Chlorine Calibration

After power is applied, the sensor must be given time to stabilize. This is best done by following the zeroing procedure below. Establishing a stable zero is critical to the proper operation of the monitor. A complete calibration will include zeroing and spanning the sensor. It is generally unnecessary to set the sensor zero unless the monitor will be used primarily for measurements below 0.5 PPM. Typical sensor zero offsets are less than 0.05 PPM and can largely be ignored in many applications.

7.11 Chlorine Zero Cal

Chlorine sensors have extremely low offset currents at zero. For this reason, it is normally sufficient to simply leave the zero at the factory default of 0.0 nA. As an alternative, an electronic zero can be set by disconnecting the sensor from the cable and performing steps 3-5 below.

If sensor zeroing is desired, the steps below will guide you through the process. This procedure assumes that the sensor has been prepared in accordance with section 5.1, Chlorine Sensor Assembly, earlier in this manual. Note that the 8 hour waiting time in step 2 below is not required if the monitor has been running for 24 hours prior to zeroing. If the unit has been running with the sensor connected, the sensor will normally return to a stable zero within 15 minutes.

1. Connect the sensor to the electronics by plugging the cable plug into the receptacle on the top of the sensor.
2. Place about an inch of water in a small beaker or other convenient container and immerse the tip of the sensor. The water used need not be distilled, but it must not contain residual chlorine. For submersible sensors, submerge the entire sensor in a bucket of unchlorinated water. Allow the sensor to sit undisturbed for at least 8 hours.
3. Scroll to the CAL menu section using the MENU key and press ENTER or the UP arrow key. **Cal Chlor** will then be displayed.
4. Press the ENTER key. The screen will display a flashing **1-Ref** for span calibration or a **2-Zer** for zero calibration. Using the UP arrow key, set for a **2-Zer** zero calibration and press ENTER.

The system now begins acquiring data for the sensor zero calibration value. As data is gathered, the units for sensor current in nanoamps (nA) and temperature may flash. Flashing units indicate that this parameter is unstable. The calibration data point acquisition will stop only when the data remains stable for a pre-determined amount of time. This can be overridden by pressing ENTER. If the data remains unstable for 10 minutes, the calibration will fail and the message **Cal Unstable** will be displayed.

5. If accepted, the screen will display the message **PASS** with the new sensor zero reading (offset), then it will return to the main measurement display. If the calibration fails, a message indicating the cause of the failure will be displayed and the FAIL icon will be turned on. The range of acceptable value for sensor offset is -25 nA to +25 nA. Should a FAIL occur, carefully inspect the sensor for a tear in the membrane. It will probably be necessary to rebuild the sensor as described in section 5.4, Chlorine Sensor Assembly. Should the offset value remain high and result in calibration failures, review the Service section of this manual, and then contact the service dept. at ATI for further assistance.

The sensor zero offset value in nA from the last zero calibration is displayed on the lower line of the Default Menus for information purposes.

7.12 Chlorine Span Cal

Span calibration of the system must be done against a laboratory measurement on the same sample that the sensor is measuring. A sample should be collected from the inlet line feeding the flow cell and quickly analyzed for free chlorine. When calibrating, it is best to have a reasonably high concentration of free chlorine in the system. The higher the value, the smaller will be the calibration errors caused by errors in the laboratory analytical procedure. It is generally preferable to calibrate at values above 0.5 PPM to reduce calibration errors. If possible, the amperometric titration procedure for free chlorine should be used as the reference method. The chlorine monitor should be calibrated while operating on a chlorinated sample stream in the flow cell assembly.

Alternately, the DPD colorimetric method may be used provided that the sample contains mainly free chlorine, with no more than a trace of chloramines. The DPD procedure will indicate high values for free chlorine if a large amount of monochloramine is present in the sample. Start flow cell and calibrate system as follows:

1. Place the previously zeroed sensor into the sensor chamber of the flow cell assembly. The sensor is inserted into the side of the flow cell and is sealed in place with a double o-ring. The o-rings are lubricated at the factory to allow the sensor to slide smoothly into place. If insertion becomes difficult, use a small amount of silicon grease to lubricate the o-rings. If the low-volume flow cell is used, screw the sensor into the flow cell until the membrane cap bottoms out on the acrylic flow cell. Do not over-tighten
2. Turn on the inlet water flow to the flow cell and adjust the inlet flow rate so that water is overflowing from the inlet chamber. The best performance will be obtained when some water is always overflowing. This maintains constant flow and pressure on the sensor at all times.
3. Allow the system to operate undisturbed for 30-60 minutes. Assuming the water contains chlorine, the display will be reading positive sensor current values. If the system is stable, the value on the display will increase to some PPM value and remain at that level. At that point, calibration can continue.
4. If the sensor is on-line, the user may want to set the output HOLD feature prior to calibration to lock out any output fluctuations.
5. Scroll to the CAL menu section using the MENU key and press ENTER or the UP arrow key. **Cal Cl₂** will then be displayed.
6. Press the ENTER key. The screen will display a flashing **1-Ref** for span calibration or a **2-Zer** for zero calibration. Using the UP arrow key, set for a **1-Ref** span calibration and press ENTER.
7. The system now begins acquiring data for the calibration value. As data is gathered, the units for ppm and temperature may flash. Flashing units indicate that this parameter is unstable. The calibration data point acquisition will stop only when the data remains stable for a pre-determined amount of time. This can be overridden by pressing ENTER. If the data remains unstable for 10 minutes, the calibration will fail and the message **Cal Unstable** will be displayed.
8. The screen will display the last measured ppm value and a message will be displayed prompting the user for the lab value. The user must then modify the screen value with the arrow keys and press ENTER. The system then performs the proper checks. Note that the monitor will wait for up to 2 hours for the user to enter the measured value for calibration. If no entry is made after 2 hours, the monitor will return to normal operation with the original slope value remaining unchanged.

9. If accepted, the screen will display the message **PASS** with the new sensor slope reading, and then it will return to the main measurement display. If the calibration fails, a message indicating the cause of the failure will be displayed and the FAIL icon will be turned on. The range of acceptable values for sensor slope is 20% to 500%. It may be necessary to rebuild the sensor as described in Section 5.1 Chlorine Sensor Preparation. Should the slope value remain out of range and result in calibration failures, review the Service Section of this manual, then contact the service dept. at ATI for further assistance.

The sensor offset value in % from the last span calibration is displayed on the lower line of the Default Menus for information purposes.

7.2 Temperature Calibration

The temperature calibration sequence is essentially a 1-point offset calibration that allows adjustments of approximately $\pm 5^{\circ}\text{C}$.

The sensor temperature may be calibrated on line, or the sensor can be removed from the process and placed into a known solution temperature reference. In any case, it is critical that the sensor be allowed to reach temperature equilibrium with the solution in order to provide the highest accuracy. When moving the sensor between widely different temperature conditions, it may be necessary to allow the sensor to stabilize as much as one hour before the calibration sequence is initiated. If the sensor is on-line, the user may want to set the output HOLD feature prior to calibration to lock out any output fluctuations.

1. Scroll to the CAL menu section using the MENU key and press ENTER or the UP arrow key.
2. Press the UP arrow key until **Cal Temp** is displayed.
3. Press the ENTER key. The message **Place sensor in solution then press ENTER** will be displayed. Move the sensor into the calibration reference (if it hasn't been moved already) and wait for temperature equilibrium to be achieved. Press ENTER to begin the calibration sequence.
4. The calibration data gathering process will begin. The message **Wait** will flash as data is accumulated and analyzed. The $^{\circ}\text{C}$ or $^{\circ}\text{F}$ symbol may flash periodically if the reading is too unstable.

5. The message **Adjust value - press ENTER** will be displayed, and the right-most digit will begin to flash, indicating that the value can be modified. Using the UP and LEFT arrow keys, modify the value to the known ref solution temperature. Adjustments up to ± 5 °C from the factory calibrated temperature are allowed. Press ENTER.

Once completed, the display will indicate **PASS** or **FAIL**. If the unit fails, the temperature adjustment may be out of range, the sensor may not have achieved complete temperature equilibrium, or there may be a problem with the temperature element. In the event of calibration failure, it is recommended to attempt the calibration again immediately.

7.3 pH Calibration

The pH calibration menus will not be seen unless the optional pH sensor input is turned ON and a pH sensor is connected to the instrument. See section 6.24 Configuration Menu [CONFIG] for more details.

The pH calibration functions appear in the CAL menu listing when the optional pH input is enabled in the CONFIG menu. When enabled, the pH input signal is used to compensate the free chlorine signal. Calibration of pH is performed in one of two methods; one-point or two-point. For new sensors or for calibration in two different pH buffers with the sensor removed from the process, choose a two-point calibration. For on-line calibrations with the sensor still mounted in the process, choose a one-point calibration. For two-point calibrations, it is highly recommended to use fresh pH buffers of 4 pH and 7 pH, or 7 pH and 9.18 pH.

The conductivity difference between the process water and the sensor reference solution can cause an effect called a “junction potential”. The junction material of the pH sensor is porous ceramic, which allows the sensor reference solution to be in electrical continuity with the process solution. One problem is caused by the reference junction and the diffusion rate of the electrolyte through the junction material. The inside surface of the junction material is in contact with the reference cell solution, which has a very high ionic strength. The outside surface of the junction material is in contact with the process water, which can have low ionic strength. This concentration gradient creates what is called a “junction potential” which can vary with the flow rate of the process. The magnitude of this potential can be upwards of 30 mV (half a pH unit). The lower the conductivity of the water the larger the effect.

It is not possible to eliminate this effect; however it usually is constant or very slow changing.

A full calibration of the pH sensor consists of an initial 2-point calibration in buffers. This sets the slope and zero offset of the sensor. The sensor should then be left in the process water for enough time for the system to fully stabilize to process conditions. This may take up to a few hours, depending on process conditions. A 1-point calibration must then be carried out. The ideal way to do this is by calibrating to a laboratory sample. After the 1-point calibration only the zero offset will have changed.

Routine calibration of the pH sensor is a 1point calibration.

7.31 Two-Point pH Cal

1. Thoroughly clean the pH sensor and place it into the first pH calibration buffer, stirring is several times before letting it rest in the beaker. Allow sensor to sit in solution long enough to achieve temperature equilibrium with the pH buffer (maybe 5 minutes.) It is important that both pH buffers be fresh and at room temperature.
2. Scroll to the CAL menu section using the MENU key and press ENTER or the UP arrow key.
3. Press the UP arrow key until **Cal pH Type** is displayed.
4. Press the ENTER key. The display will begin to flash. Using the UP arrow key, adjust the displayed number to a **2** pt calibration type. This will allow the user to offset+slope adjust the sensor input for two separate pH point. Once value has been adjusted, press the ENTER key and the message **Accepted!** will be displayed.
5. Scroll to the next menu item by pressing the UP arrow key once. The menu item **Cal pH buf1** will be displayed.
6. Press the ENTER key. The display will begin to flash. Using the UP and LEFT arrow keys, adjust the displayed number to the known value of the pH buffer. The exact temperature compensated number for pH buffers is typically written on the side of the buffers shipping container. Once value has been adjusted, press the ENTER key.
7. The message **Accepted!** will be displayed, or an error describing the cause the failure. If the cal point was accepted, rinse the sensor in distilled or de-ionized water and move it into the second pH buffer. Stir it slightly several times and let the sensor rest in the beaker.
8. Scroll to the next menu item by pressing the UP arrow key once. The menu item **Cal pH buf2** will be displayed.

9. Press the ENTER key. The display will begin to flash. Using the UP and LEFT arrow keys, adjust the displayed number to the known value of the second (higher or lower value) pH buffer. Once value has been adjusted, press the ENTER key.
10. The message **Accepted!** will be displayed, or an error describing the cause the failure. The system is now two-point calibrated for pH.

7.32 One-Point pH Cal

1. For this calibration method, the sensor may be removed, cleaned, and placed into a known pH buffer, or, it may be calibrated on-line against a known reference value. If the sensor is removed, thoroughly clean the pH sensor and place it into the pH calibration buffer, stirring several times before letting it rest in the beaker. Allow sensor to sit in solution long enough to achieve temperature equilibrium with the pH buffer (maybe 5 minutes.) It is important that the pH buffer be fresh and at room temperature.
2. Scroll to the CAL menu section using the MENU key and press ENTER or the UP arrow key.
3. Press the UP arrow key until **Cal pH Type** is displayed.

Press the ENTER key. The display will begin to flash. Using the UP arrow key, adjust the displayed number to a **1** pt calibration type. This will allow the user to offset-adjust the sensor input for one pH point. Once value has been adjusted, press the ENTER key and the message **Accepted!** will be displayed.

4. Scroll to the next menu item by pressing the UP arrow key once. The menu item **Cal pH buf1** will be displayed.
5. Press the ENTER key. The display will begin to flash. Using the UP and LEFT arrow keys, adjust the displayed number to the known value of the pH buffer. If the sensor is still mounted in the process, enter the known reference value. The exact temperature compensated number for pH buffers is typically written on the side of the buffers shipping container. Once value has been adjusted, press the ENTER key.
6. The message **Accepted!** will be displayed, or an error describing the cause the failure. The system is now two-point calibrated for pH.

7.4 Adjusting pH Compensation Curve

If the pH input is ON and the pH Comp feature is enabled (see section 6.23 Calibration Menu [CAL]), then the chlorine reading will be automatically adjusted for changes in the pH measurement. In general, chlorine readings will fall as the pH increases from 7-10 pH, and the automatic compensation feature allows a relatively constant reading to be maintained without the use of pumps and reagents. Under most conditions, all that is required to use this feature is to enable it and calibrate all sensors. The change in readings with pH changes are fairly small in the pH 7-8 range, but become more pronounced at high pH values. The default pH correction curve in the monitor is suitable for a high percentage of applications.

Years of experience have shown that the pH compensation curve is not identical in all applications. As mentioned previously, most are close to default values, but some waters exhibit curves that are significantly different. ATI Q45H/62 free chlorine monitors with software revision 4.05 and higher provide a unique method of adjusting the pH compensation curve to fit special situations.

7.41 Modifying pH Correction Values

There are actually two standard pH correction curves stored in the monitor as shown in table 7-1 below. Each curve is based on a table of 8 values. Each table entry is a pH value and an associated multiplier. The Lo Gain table is the default correction curve loaded at the factory.

Table 7-1

<u>pH</u>	<u>Lo Gain</u>	<u>Hi Gain</u>	<u>Modifications</u>
6.55	0.950	0.950	
7.05	1.000	1.000	
7.55	1.110	1.150	
8.05	1.315	1.450	
8.55	1.770	2.100	
9.05	2.540	3.200	
9.55	4.850	6.500	
10.05	7.300	9.999	

Access to the menu that allows editing of correction factors is hidden. Accidental adjustment of these values can cause large measurement errors, and editing of this data should only be done by those who thoroughly understand the impact of the changes they are making. The edit menu will not normally appear when operators are scrolling through standard menu items.

To access the table editing routines, first go to the CONFIG menu and use the Up arrow to move down to the “pH Comp” selection screen. With the display indicating pH COMP on the bottom line, press and hold the left arrow key for approximately 5 seconds. The display will change to “Edit Table”.

From this point on, you have access to 4 menus that allow for adjustment of the pH curve. They are **Edit Table**, **Load Table**, **Bkup Table**, and **AC Go**.

Edit Table: This routine allows you to change the multiplier applied to the chlorine measurement at various pH values. Use the Up arrow to review the current table values. Pressing the Up key will sequence through each of 8 pH values and the corresponding multiplier. Generally, only the multipliers at high pH will ever need adjustment, and then only rarely. If you find the monitor is over correcting, calculate the percentage of over-correction and reduce the multiplier by that percentage. If under-correcting, increase the multiplier.

Load Table: This routine allows the user to load one of two standard tables into the system. One is referred to a Lo-Gain. This table applies smaller multipliers to high pH situations and is often used for very low conductivity water. The Hi-Gain choice applies to applications where the pH dependence is much steeper at pH values above 9. The Lo-Gain table is the factory default and is loaded when your first install your monitor. Actually editing data by using the Edit Table routine requires careful testing and calculations.

Bkup Table: This routine allows the user to store an edited table or the table selected in the Load Table routine as the “Default” table. This should always be done if a change is made. If you do not store an edited table as the default, your changes could be lost. Press enter and you will be prompted for either a No or a Yes. Always answer Yes when a new table has been calculated to protect your work. The factory default is the Lo-Gain table, which is stored in the Backup Table location.

AC Go: This routine refers to “Auto Calculate”. This routine allows an operator to circulate water with a constant chlorine value through

the system, changing the pH and storing the calculated pH correction value under dynamic conditions. This routine should be used with care, and we suggest you consult an ATI technician before attempting this routine. Detailed instructions are available from ATI for using this feature, but only by request.

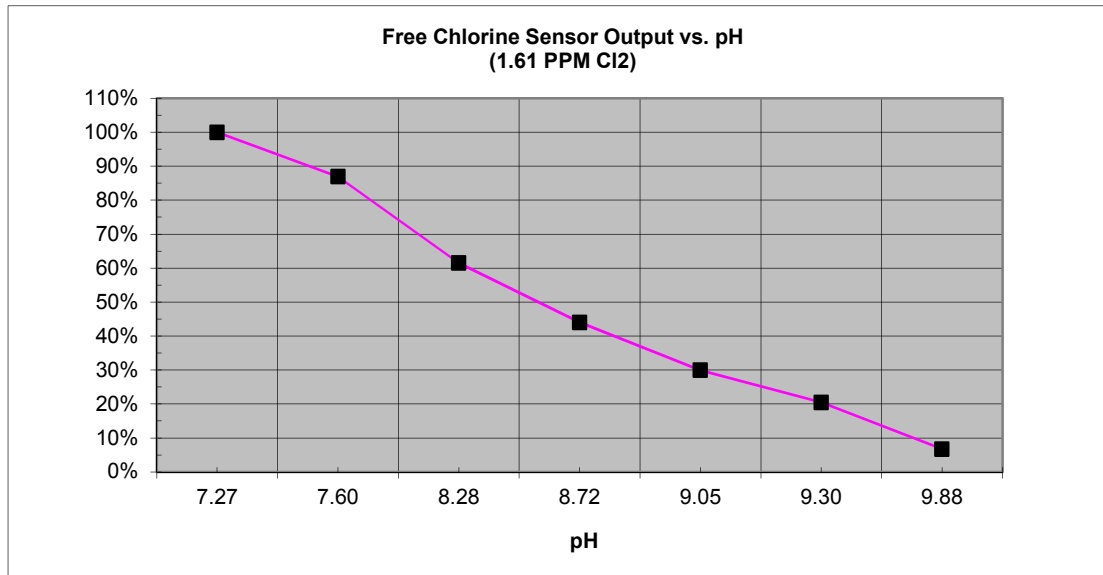

Figure 20 - Typical Free Chlorine Response to Change in pH

7.42 pH Correction – Table Modification Example

In unusual applications where sample pH can vary widely, and especially when pH values can run in the 8-10 range, default pH correction factors may not fit every application. Assume for this example that you are running a free chlorine residual of 2.0 PPM and your pH is around 8.0 but occasionally spikes up to 9.5 for short periods. The chlorine monitor correctly reads 2.0 at pH 8, but the value drops to 1.7 when the pH gets to 9.5. While not a major error, it does indicate that the pH correction multiplier applied at the 9.5 pH level is slightly lower than is needed for your application.

In order to fine tune the pH correction, you must increase the multiplier factor used at the high pH values. This can be done by editing the pH correction table. Go to the Config Menu and use the up key to move to the “pH Comp” selection. Press and hold the left arrow key for 5 seconds. The bottom line will change to “Edit Table” and the large display will indicate a pH of 6.55 (assuming the default table is running). Press the Enter key and the pH value will begin to flash. If you press the up key once you will see the multiplier for pH 6.55. Continuing to press the up key will go through each pH value and the multiplier associated with it.

When you reach the pH value of 9.55, pressing the key will display a multiplier of 4.850, again assuming no changes have been made previously. You can calculate your new multiplier value by calculating how much added multiplier is needed to get to the correct chlorine value. In this case:

$$\begin{aligned}\text{Actual Chlorine} &= 2.00 \text{ PPM} \\ \text{Displayed Chlorine} &= 1.70 \text{ PPM}\end{aligned}$$

Calculate Deviation % by dividing the difference in values, which is -.30PPM by 2.00 PPM. This is equal to -15% deviation. To correct for a negative deviation of 15%, you must increase the multiplier by the same amount.

The new multiplier then is $4.850 \times 1.15 = 5.577$.

With the original 4.850 multiplier on the display, press enter and the value will flash. Use the up key to change each digit and the left key to move from digit to digit. When done, press enter.

In this example, you have now changed your 9.55 multiplier, but the multipliers at 8.55 and 9.05 are still unchanged. If you assume that this roughly 15% under compensation is about the same above pH 8, you can go back and also increase these two multipliers by 15% as well. Since the unit is accurate at pH 8, do not change that value or any of the multipliers at lower pH values.

7.43 Storing Modified Table

If you modify the pH correction table, it is very important that you store this table properly so that it can be recovered. It would also be a good idea to write down you modified values in the blank column on the table under Section 7.41 Modifying pH Correction Values. Storing your modified table in the Backup Table memory location allows you to reload your edited table in the event that the table in the instrument becomes corrupted in some way. We call this the happy fingers recovery routine.

Once you have finished all modifications, press the menu key to return to the beginning of the "Edit Table" selection. Press the up key twice and "Bkup Table" will be displayed, with NO on the main screen. Press enter and use the up key to change the NO to YES, then press Enter. Your edited table is now the default running table. The changes you made to the edited table will also be saved if you turn power off or perform a Default All or Default Cal reset. However, if the edited table is somehow changed, you can always go to the Load Table routine and restore your edited table if necessary.

Part 8 – PID Controller Details

8.1 PID Description

PID control, like many other control schemes, are used in chemical control to improve the efficiency of chemical addition or control. By properly tuning the control loop that controls chemical addition, only the amount of chemical that is truly required is added to the system, saving money. The savings can be substantial when compared to a system which may be simply adding chemical at a constant rate to maintain some minimal addition under even the worst case conditions. The PID output controller is highly advantageous over simple control schemes that just utilize direct (proportional only) 4-20 mA output connections for control, since the PID controller can automatically adjust the “rate” of recovery based on the error between the setpoint and the measured value – which can be a substantial efficiency improvement..

The PID controller is basically designed to provide a “servo” action on the 4-20 mA output to control a process. If the user requires that a measured process stay as close as possible to a specific setpoint value, the controller output will change from 0% to 100% in an effort to keep the process at the setpoint. To affect this control, the controller must be used with properly selected control elements (valves, proper chemicals, etc.) that enable the controller to add or subtract chemical rapidly enough. This is not only specific to pumps and valves, but also to line sizes, delays in the system, etc.

This section is included to give a brief description of tuning details for the PID controller, and is not intended to be an exhaustive analysis of the complexities of PID loop tuning. Numerous sources are available for specialized methods of tuning that are appropriate for a specific application.

8.2 PID Algorithm

As most users of PID controllers realize, the terminology for the actual algorithm terms and even the algorithms themselves can vary between different manufacturers. This is important to recognize as early as possible, since just plugging in similar values from one controller into another can result in dramatically different results. There are various basic forms of PID algorithms that are commonly seen, and the implementation here is the most common version; The ISA algorithm (commonly referred to as the “ideal” algorithm.)

$$\text{output} = P \left[e(t) + \frac{1}{I} \int e(t) dt + D \frac{de(t)}{dt} \right]$$

Where:

output =	controller output
P =	proportional gain
I =	integral gain
D =	derivative gain
t =	time
e(t) =	controller error (e=measured variable – setpoint)

Figure 21 - Q45H ISA (Ideal) PID Equation

The most notable feature of the algorithm is the fact the proportional gain term affects all components directly (unlike some other algorithms - like the “series” form.) If a pre-existing controller utilizes the same form of the algorithm shown above, it is likely similar settings can for made if the units on the settings are exactly the same. Be careful of this, as many times the units are the reciprocals of each other (i.e. reps-per-min, sec-per-rep.)

PID stands for “proportional, integral, derivative.” These terms describe the three elements of the complete controller action, and each contributes a specific reaction in the control process. The PID controller is designed to be primarily used in a “closed-loop” control scheme, where the output of the controller directly affects the input through some control device, such as a pump, valve, etc.

Although the three components of the PID are described in the setting area (section 6.25 Control Menu [CONTROL]), here are more general descriptions of what each of the PID elements contribute to the overall action of the controller.

- P Proportional gain. With no “I” or “D” contribution, the controller output is simply a factor of the proportional gain multiplied by the input error (difference between the measured input and the controller setpoint.) Because a typical chemical control loop cannot react instantaneously to a correction signal, proportional gain is typically not efficient by itself – it must be combined with some integral action to be useful. Set the P term to a number between 2-4 to start. Higher numbers will cause the controller action to be quicker.

- I Integral gain. Integral gain is what allows the controller to eventually drive the input error to zero – providing accuracy to the control loop. It must be used to affect the accuracy in the servo action of the controller. Like proportional gain, increasing integral gain results in the control action happening quicker. Set the I term to a number between 3-5 to start (1-2 more than P). Like proportional gain, increasing the integral term will cause the controller action to be quicker.

- D Derivative gain. The addition of derivative control can be problematic in many applications, because it greatly contributes to oscillatory behavior. In inherently slow chemical control process', differential control is generally added in very small amounts to suppress erratic actions in the process that are non-continuous, such as pumps and valves clicking on and off. However, as a starting point for chemical process control, its best to leave the "D" term set to 0.

Based on these descriptions, the focus on tuning for chemical applications really only involves adjustment of "P" and "I" in most cases. However, increasing both increases the response of the controller. The difference is in the time of recovery. Although combinations of high "P's" and low "I" will appear to operate the same as combinations of low "P's" and high "I's", there will be a difference in rate of recovery and stability. Because of the way the algorithm is structured, large "P's" can have a larger impact to instability, because the proportional gain term impacts all the other terms directly. Therefore, keep proportional gain lower to start and increase integral gain to achieve the effect required.

Many of the classical tuning techniques have the user start with all values at 0, and then increase the P term until oscillations occur. The P value is then reduced to $\frac{1}{2}$ of the oscillatory value, and the I term is increased to give the desired response. This can be done with the Q45H controller, with the exception that the I term should start no lower than 1.0.

If it appears that even large amounts of integral gain (>20) don't appreciably increase the desired response, drop I back to about 1.0, and increase P by 1.00, and start increasing I again. In most chemical control schemes, I will be approximately 3 times the value of P.

8.3 Classical PID Tuning

Unlike many high speed position applications where PID loops are commonly used, the chemical feed application employed by this instrument does not require intense mathematical exercise to determine tuning parameters for the PID. In fact, the risk of instability is far greater with overly tuned PID control schemes. In addition, many of the classical mathematical exercises can be damaging or wasteful in the use of chemicals when the process is bumped with large amounts of input error to seek a response curve. Because of this, the general adjustment guidelines described in section 8.2 PID Algorithm are sufficient for almost all application tuning for this instrument. Beyond this, many sources are available for classical tuning methods.

8.4 Manual PID Override Control

The Q45 PID output function allows the user to take manual control of the PID control signal. This is often useful when starting up a control loop, or in the event that you wish to bump the system manually to measure system response time.

To access the manual PID control, you must be in the MEASURE mode of operation and you must have the PID output displayed on the lower line. This line will indicate “XX.X% XX.X mA” with the X values simply indicating the current values. With this display on the screen, press and hold the ENTER key for about 5 seconds. You will see a small “m” show up between the % value and the mA value. This indicates you are now in manual mode.

Once in manual, you may increase the PID output by pressing the UP arrow or you may decrease the output by pressing the LEFT arrow. This will allow you to drive the PID output to any desired setting.

To revert to normal PID control, press and hold the ENTER key again until the “m” indicator disappears.

8.5 Common PID Pitfalls

The most common problem occurring in PID control applications involves the false belief that proper settings on only the PID controller can balance any process to an efficient level.

Close-loop control can only be effective if all elements in the loop are properly selected for the application, and the process behavior is properly understood. Luckily, the nature of simple chemical control processes are generally slow in nature. Therefore, even a de-tuned controller (one that responds somewhat slowly) can still provide substantial improvements to setpoint control. In fact, damaging oscillatory behavior is far more likely in tightly tuned controllers where the user attempted to increase response too much.

When deciding on a PID control scheme, it is important to initially review all elements of the process. Sticking valves, undersized pumps, or delays in reaction times associated with chemical addition can have a dramatic effect on the stability of the control loop. When controlling a chemical mix or reaction, the sensor should be placed in a location that ensures proper mixing or reaction time has occurred.

The easiest processes to control with closed-loop schemes are generally linear, and symmetrical, in nature. For example, controlling level in tank where the opening of valve for a fixed period of time corresponds linearly to the amount that flows into a tank. Chemical control process' can be more problematic when the nature of the setpoint value is non-linear relative to the input of chemical added. For example, pH control of a process may appear linear only in a certain range of operation, and become highly exponential at the extreme ranges of the measuring scale. In addition, if a chemical process is not symmetrical, that means it responds differentially to the addition and subtraction of chemical. It is important in these applications to study steady-state impact as well as step-change impact to process changes. In other words, once the process has apparently been tuned under normal operating conditions, the user should attempt to force a dramatic change to the input to study how the output reacts. If this is difficult to do with the actual process input (the recommended method), the user can place the control in manual at an extreme control point such as 5% or 95%, and release it in manual. The recovery should not be overly oscillatory. If so, the loop needs to be de-tuned to deal with that condition (reduce P and/or I.)

Part 9 – System Maintenance

9.1 General

The Q45H/62 Free Chlorine System will generally provide unattended operation over long periods of time. With proper care, the system should continue to provide measurements indefinitely. For reliable operation, maintenance on the system must be done on a regular schedule. Keep in mind that preventive maintenance on a regular schedule is much less troublesome than emergency maintenance that always seems to come at the wrong time.

9.2 Analyzer Maintenance

No unusual maintenance of the analyzer is required if installed according to the guidelines of this operating manual. If the enclosure door is frequently opened and closed, it would be wise to periodically inspect the enclosure sealing gasket for breaks or tears.

9.3 Sensor Maintenance

Sensor maintenance is required for accurate measurements. The primary requirement is simply to keep the sensor membrane clean. The membrane is a micro-porous polymer that is resistant to anything that will be encountered in water streams. However, deposits can form on the surface or in the pores of the membrane, and these deposits will reduce the sensitivity. Certain constituents in water, mainly iron and manganese, will form precipitates when the water is chlorinated. These precipitates can sometimes form a coating on the membrane.

Because membranes are micro-porous, they can be relatively difficult to clean effectively. Immersing the tip of the sensor in 1N nitric acid solution will sometimes remove deposits that cause low sensitivity, but this is not always the case. The recommended practice is to simply replace the membrane when it becomes fouled. To change a membrane, follow the Sensor Assembly procedure (see section 5.1 Chlorine Sensor Preparation). Do not reuse the electrolyte from the sensor when changing a membrane. Always refill with fresh electrolyte. The electrolyte is stable and does not have a limited shelf life.

Refer again to the explanation of the sensor slope number after an accepted span calibration on the lower MEASURE screen. In normal operation, the slope of the sensor output will decrease over time as the membrane becomes fouled. This reduction indicates that the sensor is losing sensitivity to chlorine. It is good practice to replace the membrane if the slope number falls to 30-40%. The value will not go below 20%.

Even if no buildup is apparent on the membrane, it should be changed on a regular schedule. The recommended membrane change interval is every 3 months. For high purity water applications, this can probably be extended if desired, but a more frequent changing interval is a small price to pay for avoiding membrane failure at the wrong time.

While the sensor is disassembled for membrane changing, examine the condition of the o-rings on both ends of the electrolyte chamber. If the o-rings show any signs of damage, replace them with new ones from the spare parts kit. It is good practice to change these o-rings once a year, regardless of their condition.

9.4 Sensor Acid Cleaning

Over an extended operating period, chlorine sensors can slowly accumulate deposits on the surface of the platinum electrode. Typically, this type of buildup occurs over years of operation, but can sometimes occur more quickly if high levels of manganese, iron, or other metals are dissolved in the water. The platinum electrode can be “acid cleaned” using nitric acid solutions.

WARNING

THIS ACID CLEANING PROCEDURE INVOLVES THE USE OF HIGHLY CORROSIVE ACID SOLUTIONS. IT SHOULD ONLY BE COMPLETED BY TRAINED PERSONNEL USING PROTECTIVE EYEWEAR AND GLOVES. IF THERE IS ANY DOUBT ABOUT YOUR ABILITY TO SAFELY ACCOMPLISH THIS PROCEDURE, RETURN THE SENSOR TO ATI FOR FACTORY CLEANING!

To acid clean the electrode assembly, remove the electrolyte chamber from the sensor so that the so that both electrodes are exposed. Then follow the procedure below.

1. Place a small amount of 50% nitric acid solution in a beaker. Put in just enough so that the platinum tip of the sensor can be submerged without any contact with the silver coil.
2. Allow the sensor to soak in this acid solution for 2 minutes. Remove the sensor body and rinse the platinum tip thoroughly with distilled water. Discard the nitric acid safely and according to all environmental regulations.

3. Fill the beaker with distilled water to the level sufficient to submerge both the tip and the silver coil. Do not allow the connector at the back of the sensor to be submerged. Allow the electrodes to soak in distilled water for 30 minutes.
4. Put a new membrane and fresh electrolyte in the electrolyte chamber and reassemble the sensor. Connect to the chlorine monitor electronics and allow the sensor to stabilize for at least 24 hours. The sensor can be placed in the flow cell with chlorinated water running through it during stabilization. However, the readings will not be useful for 24 hours.

9.5 Q22P Sensor Cleaning

Keep the sensor as clean as possible for optimum measurement accuracy - this includes both the saltbridge and the measuring electrode glass. Frequency of cleaning depends upon the process solution.

Carefully wipe the measuring end of the sensor with a clean soft cloth. Then rinse with clean, warm water - use distilled or de-ionized water if possible. This should remove most contaminate buildup.

Prepare a mild solution of soap and warm water. Use a non-abrasive detergent (such as dishwashing liquid).

NOTE: DO NOT use a soap containing any oils (such as lanolin). Oils can coat the glass electrode and harm sensor performance.

Soak the sensor for several minutes in the soap solution.

Use a small, extra-soft bristle brush (such as a mushroom brush) to thoroughly clean the electrode and saltbridge surfaces. If surface deposits are not completely removed after performing this step, use a dilute acid to dissolve the deposits. After soaking, rinse the sensor thoroughly with clean, warm water. Placing the sensor in pH 7 buffer for about 10 minutes will help to neutralize any remaining acid.



NOTE: DO NOT soak the sensor in dilute acid solution for more than 5 minutes. This will help to prevent the acid from being absorbed into the saltbridge.

WARNING: ACIDS ARE HAZARDOUS. Always wear eye and skin protection when handling. Follow all Material Safety Data Sheet recommendations. A hazardous chemical reaction can be created when certain acids come in contact with process chemicals. Make this determination before cleaning with any acid, regardless of concentration.

9.6 Replacing the Saltbridge and Reference Buffer Solution

1. Hold the sensor with the process electrode pointing up. Place a cloth or towel around the saltbridge. Turn the saltbridge counterclockwise (by hand) to loosen and remove the saltbridge. Do NOT use pliers.
2. Pour out the old reference buffer by inverting the sensor (process electrode pointing down). If the reference buffer does not run out, gently shake or tap the sensor.
3. Rinse the reference chamber of the sensor with de-ionized water. Fill the reference chamber of the sensor with fresh Reference Cell Buffer. The chamber holds 6 to 7 mL of solution. MAKE SURE that 6 to 7 mL is used when refilling. The chamber should be FULL.
4. Inspect the new saltbridge to verify that there are 2 o-rings inside the threaded section of the saltbridge
5. Place the new saltbridge over the ground assembly of the sensor. Place a cloth or towel around the saltbridge and hand-tighten the saltbridge by turning it clockwise.



NOTE: Every ATI Q25P Sensor includes a spare bottle of Reference Buffer Solution, 7.0 pH. This is NOT typical pH 7 buffer, it is a special “high-capacity” buffer developed to ensure the highest possible stability of the reference portion of the pH measurement. No substitutions should be made.

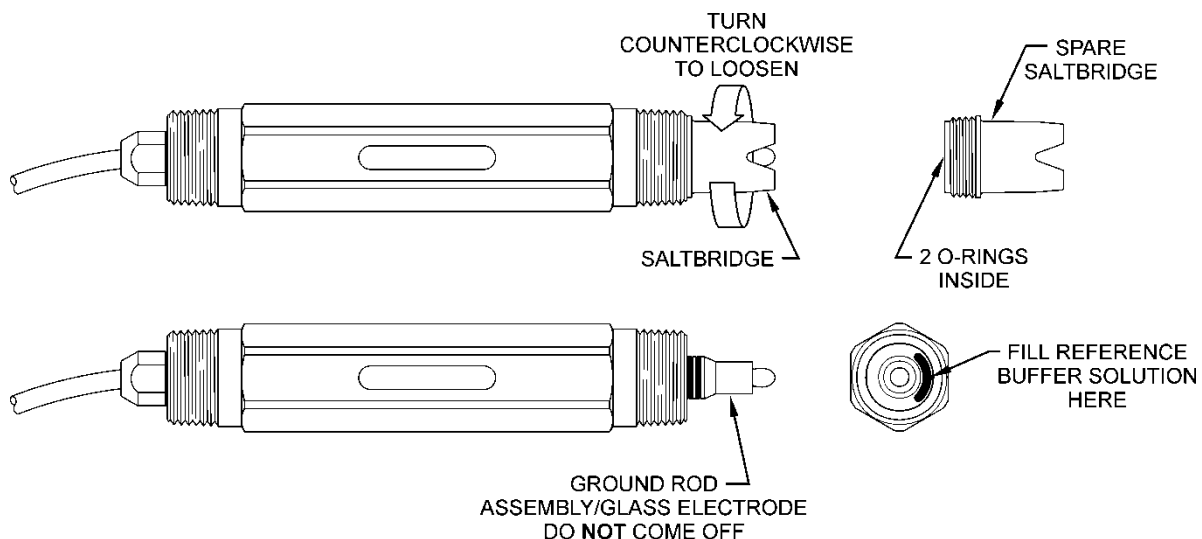

Figure 22 - Replacing the Saltbridge and Reference Buffer

9.7 Flow Cell Maintenance

The maintenance on the flow cell is simple cleaning. The flow cell is clear to make examination of the condition of the sensor easier without interfering with operations. The flow cell may be cleaned by wiping or by washing with detergents or dilute acids. Do not try to clean with solvents as the acrylic may craze or crack.

Change the o-ring in the flow cell yearly or if any damage is observed. If insertion of the sensor into the flow cell becomes difficult, use silicon grease to lubricate the o-rings that hold the sensor in place. Use only enough grease to provide surface lubrication. Excess grease could foul the sensor membrane.

Part 10 – Troubleshooting

10.1 General

The information included in this section is intended to be used in an attempt to quickly resolve an operational problem with the system. During any troubleshooting process, it will save the most time if the operator can first determine if the problem is related to the analyzer, sensor, or some external source. Therefore, this section is organized from the approach of excluding any likely external sources, isolating the analyzer, and finally isolating the sensor. If these procedures still do not resolve the operational problems, any results the operator may have noted here will be very helpful when discussing the problem with the factory technical support group.

10.2 External Sources of Problems

To begin this process, review the connections of the system to all external connections.

1. Verify the analyzer is earth grounded. For all configurations of the analyzer, an earth ground connection **MUST** be present for the shielding systems in the electronics to be active. Grounded conduit provides no earth connection to the plastic enclosure, so an earth ground wiring connection must be made at the power input terminal strip. Verify metal shield is present over incoming power connections. This shield is for safety purposes, but also blocks electrical spikes from relay and power wiring.
2. Verify the loads on any 4-20 mA outputs do not exceed the limits in the Instrument Specifications. During troubleshooting, it is many times helpful to disconnect all these outputs and place wire-shorts across the terminals in the instrument to isolate the system and evaluate any problems which may be coming down the analog output connections.
3. Do not run sensor cables or analog output wiring in the same conduits as power wiring. If low voltage signal cables must come near power wiring, cross them at 90° to minimize coupling.
4. If rigid conduit has been run directly to the Q45 enclosure, check for signs that moisture has followed conduit into the enclosure.

5. Check for ground loops. Although the membrane sensor is electrically isolated from the process water, high frequency sources of electrical noise may still cause erratic behavior in extreme conditions. If readings are very erratic after wiring has been checked, check for a possible AC ground loop by temporarily disconnecting feed and drain lines from the flow cell while there is still water on the inside. The reading should be initially stable and then fall very slowly in a smooth fashion as chlorine is depleted in the static sample.
6. Carefully examine any junction box connections for loose wiring or bad wire stripping. If possible, connect the sensor directly to the analyzer for testing.
7. Check sensor membrane for fouling. Look closely for signs of grease or oil which may be present. Replace membrane and electrolyte, allow to stabilize, and re-check. The procedure for 5.1 Chlorine Sensor Preparation must be followed when replacing the membrane.
8. Check pH of water sample. High pH conditions can cause low sensitivity. If pH is above 8.2, contact ATI for information on carbon dioxide buffer systems.
9. Check to see that the chlorine in the water is free chlorine and not combined chlorine. The free chlorine sensor has almost no sensitivity to monochloramine.

10.3 Analyzer Tests

1. Disconnect power and completely disconnect all output wiring coming from the analyzer. Remove sensor wiring, relay wiring, and analog output wiring. Re-apply power to the analyzer.
2. Using the Simulate feature, check operation of analog outputs and relays with a DMM.
3. Check cell drive circuit. With a digital voltmeter (DVM), measure the voltage between ORANGE (-) and WHITE (+) terminals. Verify that the millivolt value is actually -200mV.
4. Check TC drive circuit. Place a wire-short between the GREEN and BLACK terminals. With a digital voltmeter (DVM), measure the voltage between the BLACK and RED terminals on the back of the monitor to verify that the TC drive circuit is producing about 4.8-5.1 VDC open circuit. Remove DVM completely and connect a 100 Ohm resistor from the BLACK to RED terminals. The temperature reading should display approximately 0°C and the chlorine reading should display approximately 0 ppm.

10.4 Display Messages

The Q45 Series instruments provide a number of diagnostic messages which indicate problems during normal operation and calibration. These messages appear as prompts on the secondary line of the display or as items on the Fault List.

MESSAGE	DESCRIPTION	POSSIBLE CORRECTION
Max is 200	Entry failed, maximum user value allowed is 200.	Reduce value to ≤ 200
Min is 20	Entry failed, minimum value allowed is 20.	Increase value to ≥ 20
Cal Unstable	Calibration problem, data too unstable to calibrate. Icons will not stop flashing if data is too unstable. User can bypass by pressing ENTER.	Clean sensor, get fresh cal solutions, allow temperature and conductivity readings to fully stabilize, do not handle sensor or cable during calibration.
Out of Range	Input value is outside selected range of the specific list item being configured.	Check manual for limits of the function to be configured.
Locked!	Transmitter security setting is locked.	Enter security code to allow modifications to settings.
Unlocked!	Transmitter security has just been unlocked.	Displayed just after security code has been entered.
Offset High	The sensor zero offset point is out of the acceptable range of -25 to +25 nA.	Check wiring connections to sensor. Allow sensor to operate powered a minimum of 12 hours prior to first zero cal.
Sensor High	The raw signal from the sensor is too high and out of instrument range.	Check wiring connections to sensor.
Sensor Low	The raw signal from the sensor is too low.	Check wiring connections to sensor.
Chlor High	The chlorine reading is greater than the maximum of the User-selected range.	The chlorine reading is over operating limits. Set measuring range to the next highest level.
Temp High	The temperature reading is $> 55^{\circ}\text{C}$.	The temperature reading is over operating limits. Check wiring and expected temp level. Perform RTD test as described in sensor manual. Recalibrate sensor temperature element if necessary.

Figure 23 - Q45H Display Messages

MESSAGE	DESCRIPTION	POSSIBLE CORRECTION
Temp Low	The temperature reading is < -10 °C	Same as “Temp High” above.
TC Error	TC may be open or shorted.	Check sensor wiring and perform RTD test as described in sensor manual. Check j-box connections.
Chlor Cal Fail	Failure of chlorine calibration. FAIL icon will not extinguish until successful calibration has been performed, or 30 minutes passes with no keys being pressed.	Clean sensor redo zero and span calibration. If still failure, sensor slope may be less than 25% or greater than 250%. Perform sensor tests as described in section 10.5. Replace sensor if still failure.
TC Cal Fail	Failure of temperature calibration. FAIL icon will not extinguish until successful calibration has been performed, or 30 minutes passes with no keys being pressed.	Clean sensor, check cal solution temperature and repeat sensor temp calibration. TC calibration function only allows adjustments of +/- 6 °C. If still failure, perform sensor tests as described in section 10.5. Replace sensor if still failure.
EPROM Fail	Internal nonvolatile memory failure	System failure, consult factory.
Checksum Fail	Internal software storage error.	System failure, consult factory.
Display Fail	Internal display driver fail.	System failure, consult factory.
Range Cal Fail	Failure of factory temperature calibration.	Consult factory.

Figure 24 - Q45H Display Messages (Continued)

10.5 Sensor Tests

1. Check the membrane condition. A membrane that is not stretched smoothly across the tip of the sensor will cause unstable measurements. If necessary, change membrane and electrolyte.
2. Residual chlorine sensors can be tested with a digital voltmeter (DVM) to determine if a major sensor problem exists. Follow the steps below to verify sensor integrity:
 - A. Disconnect the five sensor wires from the back of the chlorine monitor. Those wires are color coded white, brown, red, black, and green. Note that the brown wire may be replaced with an orange wire in some cables.
 - B. Remove the electrolyte chamber from the sensor and dry the electrodes with a paper towel.
 - C. Connect a DVM between the white and brown (or orange) wires. Reading resistance, you should find an open circuit value of infinite resistance. There must be no measurable resistance at all between these wires. Any resistance at all indicates either water in the cable connector or the breakdown in an electrode seal.
 - D. Connect a DVM between the red and white wires. The red wire is part of the RTD circuit and the white wire is part of the measuring cell. There should be no connection. Reading resistance, you should find an open circuit value of infinite resistance. Any resistance at all indicates either water in the cable connector or the breakdown in an electrode seal.
 - E. Connect the DVM between the red and black wires. These are the RTD leads, and you should find a resistance value that depends on the temperature. The table below lists the resistance values for various temperatures. Reading resistance between the red and green wires should give exactly the same values as between red and black.

Temperature °C	Resistance Ω
0	100.0
5	101.9
10	103.9
15	105.8
20	107.8
25	109.7
30	111.7
35	113.6
40	115.5
45	117.5
50	119.4

Figure 25 - Pt100 RTD Table

If you suspect that water has gotten into a cable connection on a flow type sensor or into the plug connection of a submersible sensor, disconnect the cable and allow the parts of the sensor to sit in a warm place for 24 hours. If water in the connector is the problem, it should dry out sufficiently to allow normal sensor operation. However, steps 2c thru 2e above will have to be repeated after drying to see if the problem is gone.

3. Acid clean the sensor electrodes in accordance with the procedure on the previous page.

10.6 Troubleshooting (Q22P Sensor)

The first step in resolving any measurement problem is to determine whether the trouble lies in the sensor or the transmitter. Since measurement problems can often be traced to dirty sensor electrode glass and/or saltbridge, cleaning the sensor using the method outlined in Section 9 should always be the first step in any troubleshooting.

If the sensor cannot be calibrated after cleaning, replace the saltbridge and reference cell buffer pH 7 as outlined in Section 9.

If the sensor still cannot be calibrated, perform the following test. A multimeter, pH 7 buffer and pH 4 buffer will be needed.

1. With transmitter power on and sensor connected, place the multimeter's positive (+) lead on the white position of the transmitter terminal strip and the negative (-) lead on the black position. The multimeter should read between -4.2 and -6.5 VDC.
2. Disconnect the sensor's black and red wires from the transmitter or junction box. Re-check Step 1.
3. Place the sensor in pH 7 buffer. As in calibration, allow the temperatures of the sensor and buffer to equilibrate at room temperature (approximately 25 °C).
4. Connect the multimeter's positive (+) lead to the red wire and its negative (-) lead to the black wire. With the sensor in the pH 7 buffer at approximately 20-30 °C, measure the DC millivolts. The sensor reading should be between 680 – 750 mV. If it is not, replace sensor reference solution, saltbridge and re-test.
5. With the multimeter connected as in Step 4, rinse the sensor with clean water and place it in the pH 4 buffer. Allow the temperatures to equilibrate as before. Now measure the sensor span reading. It should be between +450 – 550 mV.

Spare Parts

Part No.

Description

Spare Electronics

07-0023	Q45H RCl ₂ monitor, loop-powered
05-0058	Q45 Mounting Kit
03-0338-0	Q45H/62 Front Lid Assy
31-0173	Ribbon Cable, 20 pin

Spare Sensors

07-0096	Q22 pH Sensor (Convertible / Flowcell)
07-0132	Q22 pH Sensor (Submersible)
00-0066	Flow, Free Cl ₂ Sensor
02-0016	Flow RCl ₂ sensing element body (for #00-0066)
00-0067	Submersible RCl ₂ Sensor with 25' cable
02-0021	Submersible RCl ₂ sensing module (for #00-0067)
02-0017	Submersible RCl ₂ sensing element body (for #02-0021)
05-0066	Salt Bridge (for 07-0096 Sensor)
09-0052	Internal buffer for 07-0096 pH Sensor
63-0098	Conventional pH sensor with 18" cable
63-0101	Conventional pH sensor with 25 ft. cable

Spare Sensor Components

02-0031	Submersion holder, 25' cable (for #00-0067)
03-0029	Sensor interconnect cable, 25ft.
45-0007	Electrolyte chamber for Free Chlorine Sensor (00-0066)
45-0010	Membrane Holder, Noryl
48-0001	Membrane holder, type 316 stainless steel
48-0160	Membrane Holder, titanium, small front bore
05-0005*	Membranes, free chlorine, pkg. of 10
05-0004*	Spare Parts Kit, screw & o-ring, (for flow/In-line sensor)
05-0010	Spare Parts Kit, screw & o-ring, (for submersible sensor)
09-0011*	Electrolyte, 4 oz (120 cc), free chlorine

Spare Flowcells

00-0043	Constant head flowcell assembly with mounting plate
00-0633	Low volume flowcell assembly
42-0014	Flowcell o-ring (each)
00-1522	Sealed flowcell for Cl ₂ sensor
00-1527	Sealed flowcell for conventional pH sensor
45-0268	Standard pH (63-0101) flow cell adapter

Spare Parts (Cont'd)

Misc Components

07-0100	Junction Box
07-0382	Junction Box for 2 nd Input Sensor
31-0038	Interconnect Cable (per ft.)
44-0260	Pg9 Cord Grip (each)
44-0009	Pg11 Cord Grip (each)
03-0372	Fixed Flow Regulator Assy
05-0110	Sealed Flowcell Vacuum Breaker Assy

Note: Instrument is supplied with sufficient spare parts for 6-12 months of operation. For 2 year spare parts inventory, 3 each of the items marked with an asterisk are required.

Lock/Unlock Code: 1456