

Tank level gauge for cryogenic and liquefied gas

Model TLG

Max. Static pressure 100 bar

Nominal size: 100 mm (4"), 150 mm (6")

Accuracy: Class 1,6 (1.6%)

Features

- Stainless steel case and wetted parts
- Suitable for liquids, gases or vapors
- Max static pressure 100 bar
- IP65

Ranges

0 ... 65 in H₂O up to 0 ... 60 psi

0 ... 1600 mmWC up to 0 ... 4 bar & kg/cm²

0 ... 16 kPa up to 0 ... 400 kPa

Applications

Level measurements in cryogenic tanks and closed containers

Machine and apparatus construction

Differential pressure measurement across valves and filters

Flow rate measurement by differential pressure

Technical specification	TLG	
	100	150
Dial size for DP gauge in mm	100	150
Dial size for pressure gauge	100 mm standard, optional 63 mm	
Construction	Cylindrical case indicator mounted on 3 valve manifold with pressure gauge	
Measuring principle of DP gauge	Single diaphragms	
Pressure type	Differential	
Measuring range	1600 2500 4000 6000 mmWC 1 1.6 2.5 4 kg/cm ²	
Static Pressure (DP Gauge)	100 bar both side	
Overload capability (DP Gauge)	200% of range	
Overload capacity (Pressure Gauge)	130% of range	
Accuracy	Class 1,6 (1,6 % F.S.)	
C-C distance for process manifold	54 mm standard, 31 mm and 37 mm on request	
C-C distance for DP gauge mounting	54 mm standard	
Process connections	1/4" NPT (F), 1/2" NPT (F), 1/4" NPT (M), 1/2" NPT (M), 1/4" BSP (M), 1/2" BSP (M), others on request	
Test connection	1/2" NPT (F) with plug, others on request	
Connection location	Lower	
Material		
Measuring diaphragm	Stainless steel 316L for ranges ≤2.5 bar Duratherm for ranges > 2.5 bar	
Pressure chamber	Stainless steel 316L	
Bourdon tube	Stainless steel 316L	
Socket and connectors	Stainless steel 316L	
Case/bayonet ring	Stainless steel 304, optional 316	
Window	Laminated safety glass	
Dial	Aluminum, black markings on white background	
Pointer	Aluminum, black with micrometer adjustment	
Packing for manifold	PTFE	
Permissible		
Zero shift for DP gauge	±2% at maximum static pressure	
Ambient temperature	-40 ... 60 °C (-40 ... 140 °F)	
Medium temperature	Max. 100 °C (212 °F)	
Storage temperature	-40 ... 65 °C (-40 ... 150 °F)	
Effect	Max. 0,6 % / 10 K	
Protection according EN 60 529/IEC 529	IP65 as per EN/IEC 60529	
Filling liquids	Glycerin, silicone, others on request	
Mounting	Direct, optional 2" pipe mounting	
Other accessories	NACE, Electrical contacts, pressure transmitters, etc	

General dimensions in mm

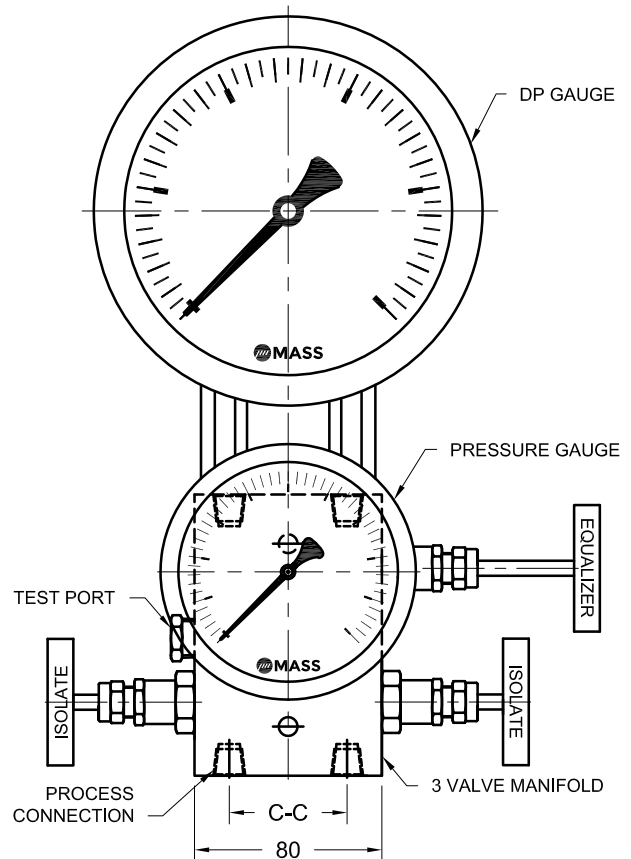
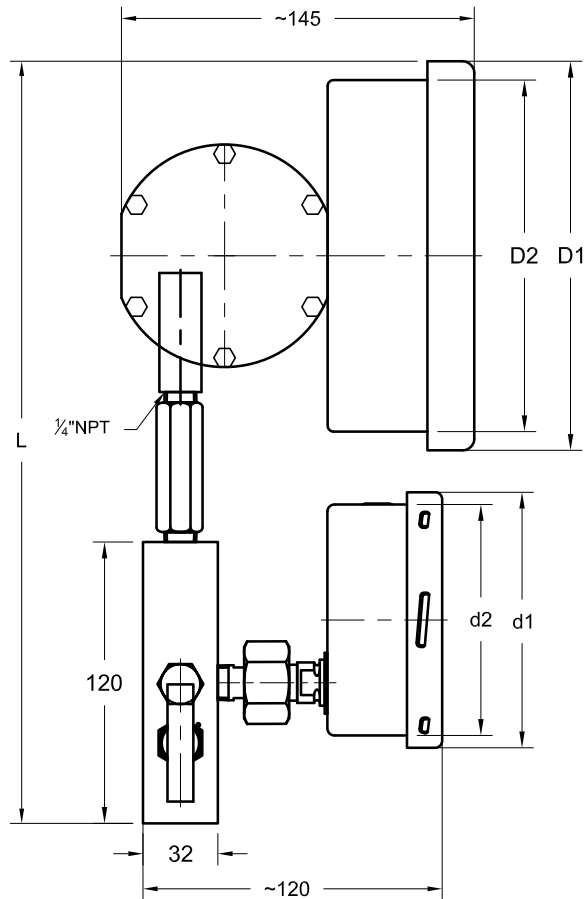

PRESSURE GAUGE	
DIAL SIZE	63 100
d1	68.6 109
d2	61.6 98.5

DP GAUGE	
DIAL SIZE	100 150
D1	118 166
D2	103 150
L	~320 ~340

Order information

DP gauge Size	Type	Pressure gauge Size	C-C distance	Process connection	DP gauge Range	Engineering unit	Pressure gauge Range	Engineering unit	Options
(100) 100 mm	TLG	(63) 63 mm	(54) 54 mm	(02) 1/4" NPT (M)	0/1600 ¹⁾ 0/2500 ¹⁾	mmWC	0/ 0,6 0/ 1	kg/cm ² (or bar)	(NH) Tagging wired (CS) Dual scale (DA) Dial marking (OF) Oil free (TM) 2" pipe mounting bracket
(150) 150 mm		(100) 100 mm	(37) 37 mm (31) 31 mm	(04) 1/2" NPT (M) (13) 1/4" BSP (M) (15) 1/2" BSP (M) (02T) 1/4" NPT (F)	0/4000 0/6000 0/ 0,6 0/ 1 0/ 1,6 0/ 2,5 0/ 4		0/ 1,6 0/ 2,5 0/ 4 0/ 6 0/ 10 0/ 16 0/ 25 0/ 40		
					Range to be selected as per Tank Height	Equivalent ranges in kPa, MPa, psi, bar and others units available	Range to be selected as per Tank Static Pressure	Equivalent ranges in kPa, MPa, psi, bar and others units available	

1) Dial arc shall be 180°

Order example

DP gauge Size	Type	Pressure gauge Size	C-C distance	Process connection	DP gauge Range	Engineering unit	Pressure gauge Range	Engineering unit	Option
100	TLG	100	54	02T	0/4000	mmWC	0/40	KG/CM ²	NH

Precision Mass Products Pvt. Ltd.

Plot No.: 2306, G.I.D.C. Chhatral, Ta: Kalol, Dist.: Gandhinagar, Chhatral -382729, Gujarat, India.

Telephone: +91-2764 233681/82/83

Email: sales@precisionmass.com

Fax: +91-2764-233440

www.precisionmass.com

- North Zone : sales.delhi@precisionmass.com
- East zone : sales.kolkata@precisionmass.com
- West zone : sales.mumbai@precisionmass.com
- South zone : sales.chennai@precisionmass.com